

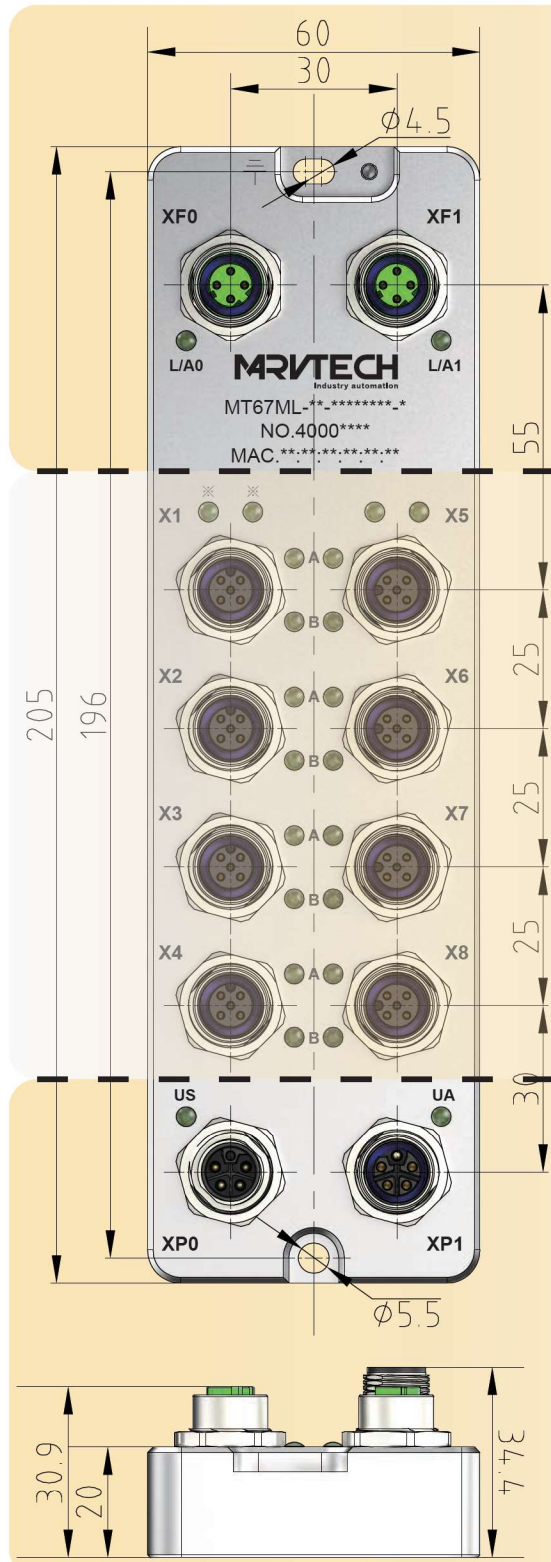

**IP67-MT67ML
Network Module**



Pin Definition (Data Port)			
M12 D-code Female	Connection Type	2 x M12 D-code; 4-pin Female	XF0 , XF1 1. TX+ 2. RX+ 3. TX- 4. RX-
	Physical layer	Ethernet	
	Transfer rate	10/100 Mbps, Full Duplex	
	Min. Cycle Time	1 ms	
	Port fixed torque	M12 : 0.5Nm	

Basic parameters	
Housing material	Aluminum alloy
Housing color	Metallic Silver
Protection level	IP67
Dimensions (W x H x D)	205mm x 60mm x 34.4mm
Weight	515g
Operating temperature	-25°C...70°C
Storage temperature	-40°C...85°C
Operating humidity	5%...95%
Storage humidity	5%...95%
Operating Atmospheric pressure	80KPa...106KPa
Storage Atmospheric pressure	80KPa...106KPa
Tightening torque(I/O)	M12:0.5Nm
Application Environment	According EN-61131
Vibration Test	According IEC60068-2
Impact Test	According IEC60068-27
Free Drop Test	According IEC60068-32
EMC	According IEC61000-4-2,-3,-4
Certification	CE,RoHS
Mounting Hole size	Φ4.5mm x 1, Φ5.5mm x 1

Pin Definition (Power Port)			
Power Supply Port	Connection Type	M12, 5pol, L-code, Female&Male	XP0 XP1 Male Female 1. +24V_Us 2. GND_Ua 3. GND_Us 4. +24V_Ua 5. FE
	System voltage Us	18...30 VDC (type.24VDC)	
	Auxiliary voltage Ua	18...30 VDC (type.24VDC)	
	Current sum Is	12A	
M12 L-code Female& Male	Current sum Ia	12A	
	No-load current Ic	≤150mA	
	Reverse power protection	Yes	
	Tightening torque (Power)	M12:0.5Nm	



IP67-MT67ML Series Network Module

Order Information				
Interface	Model	Order No.	Description	I/O Connection Type
	MT67ML-EC-DI16P	40000141	16 channel , PNP, Digital Input, IP67 Network Module	M12, 5pin Female, A-code
	MT67ML-PN-DI16P	40000126		
	MT67ML-EI-DI16P	40000014		

Digital Input	
Digital Inputs	Max. 16
Input Type	3-wire PNP sensor or 2 wire passive signal
Voltage	11...30 VDC
Supply Current	< 200mA
Switch threshold	EN 61131-2 Type 1/3
Switch frequency	250 Hz
Input delay	20 µs
Max. input current	6 mA

Module LED					
EtherCat		ProfiNet		EtherNet/IP	
PWR	GN: module power normally				
	RD: module power reverse				
I/O	GN: channel signal normally				
	RD: port power supply short circuit				
LINK	GN: Link normally				
	YE flash: data transmission normally				
	Light off: module unlinked				
RUN	GN: OP status	SF	RD: module fault	MS	GN: module work normally
	GN flash (slowly): SAFEOP status		RD: Internal error		GN flash: unconfigured / unlinked
	GN flash (quickly): Pre-OP status	BF	RD flash: device Name / IP error	NS	RD: device Name / IP error
	light off: Init status		RD flash: communication error		GN: Network normally
ERR	RD flash: communication error			NS	GN flash: Network unlinked
	Light off: module work normally				RD flash: communication error

Pin Definition (I/O port)																																						
I/O port	Pins	Address																																				
	M12 A-code Female	<p>M12(X1~X8)</p> <p>PNP</p> <p>Input</p> <ol style="list-style-type: none"> 24 VDC+ Input 0 V Input FE 	<table border="1"> <thead> <tr> <th>Byte</th> <th>0</th> <th>Byte</th> <th>1</th> </tr> </thead> <tbody> <tr> <td>Bit0</td> <td>X1P4</td> <td>Bit0</td> <td>X1P2</td> </tr> <tr> <td>Bit1</td> <td>X2P4</td> <td>Bit1</td> <td>X2P2</td> </tr> <tr> <td>Bit2</td> <td>X3P4</td> <td>Bit2</td> <td>X3P2</td> </tr> <tr> <td>Bit3</td> <td>X4P4</td> <td>Bit3</td> <td>X4P2</td> </tr> <tr> <td>Bit4</td> <td>X5P4</td> <td>Bit4</td> <td>X5P2</td> </tr> <tr> <td>Bit5</td> <td>X6P4</td> <td>Bit5</td> <td>X6P2</td> </tr> <tr> <td>Bit6</td> <td>X7P4</td> <td>Bit6</td> <td>X7P2</td> </tr> <tr> <td>Bit7</td> <td>X8P4</td> <td>Bit7</td> <td>X8P2</td> </tr> </tbody> </table>	Byte	0	Byte	1	Bit0	X1P4	Bit0	X1P2	Bit1	X2P4	Bit1	X2P2	Bit2	X3P4	Bit2	X3P2	Bit3	X4P4	Bit3	X4P2	Bit4	X5P4	Bit4	X5P2	Bit5	X6P4	Bit5	X6P2	Bit6	X7P4	Bit6	X7P2	Bit7	X8P4	Bit7
Byte	0	Byte	1																																			
Bit0	X1P4	Bit0	X1P2																																			
Bit1	X2P4	Bit1	X2P2																																			
Bit2	X3P4	Bit2	X3P2																																			
Bit3	X4P4	Bit3	X4P2																																			
Bit4	X5P4	Bit4	X5P2																																			
Bit5	X6P4	Bit5	X6P2																																			
Bit6	X7P4	Bit6	X7P2																																			
Bit7	X8P4	Bit7	X8P2																																			

Order Information				
Interface	Model	Order No.	Description	I/O Connection Type
	MT67ML-EC-DI16N	40000220	16 channel input, NPN IP67 Network Module	M12, 5pin Female, A-code
	MT67ML-PN-DI16N	40000127		
	MT67ML-EI-DI16N	40000015		

Digital Input	
Digital Inputs	Max. 16
Input Type	3-wire NPN sensor or 2-wire passive signal
Voltage	0...5 VDC
Diagnosis	Power supply short circuit diagnosis
Switch threshold	EN 61131-2 Type 1/3
Switch frequency	250 Hz
Input delay	20 µs
Max. input current	6 mA

Module LED					
EtherCat		ProfiNet		EtherNet/IP	
PWR	GN: module power normally				
	RD: module power reverse				
I/O	GN: channel signal normally				
	RD: port power supply short circuit				
LINK	GN: Link normally				
	YE flash: data transmission normally				
	Light off: module unlinked				
RUN	GN: OP status	SF	RD: module fault	MS	GN: module work normally
	GN flash (slowly): SAFEOP status		RD: Internal error		GN flash: unconfigured / unlinked
	GN flash (quickly): Pre-OP status	BF	RD flash: device Name / IP error	NS	RD: device Name / IP error
	light off: Init status		RD flash: communication error		GN: Network normally
ERR	RD flash: communication error			NS	GN flash: Network unlinked
	Light off: module work normally				RD flash: communication error

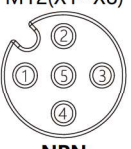
Pin Definition (I/O port)																																						
I/O port	Pins	Address																																				
M12 A-code Female	 <p>M12(X1~X8) NPN</p> <p>Input</p> <p>1. 24 VDC+ 2. Input 3. 0 V 4. Input 5. FE</p>	<table border="1"> <thead> <tr> <th>Byte</th> <th>0</th> <th>Byte</th> <th>1</th> </tr> </thead> <tbody> <tr> <td>Bit0</td> <td>X1P4</td> <td>Bit0</td> <td>X1P2</td> </tr> <tr> <td>Bit1</td> <td>X2P4</td> <td>Bit1</td> <td>X2P2</td> </tr> <tr> <td>Bit2</td> <td>X3P4</td> <td>Bit2</td> <td>X3P2</td> </tr> <tr> <td>Bit3</td> <td>X4P4</td> <td>Bit3</td> <td>X4P2</td> </tr> <tr> <td>Bit4</td> <td>X5P4</td> <td>Bit4</td> <td>X5P2</td> </tr> <tr> <td>Bit5</td> <td>X6P4</td> <td>Bit5</td> <td>X6P2</td> </tr> <tr> <td>Bit6</td> <td>X7P4</td> <td>Bit6</td> <td>X7P2</td> </tr> <tr> <td>Bit7</td> <td>X8P4</td> <td>Bit7</td> <td>X8P2</td> </tr> </tbody> </table>	Byte	0	Byte	1	Bit0	X1P4	Bit0	X1P2	Bit1	X2P4	Bit1	X2P2	Bit2	X3P4	Bit2	X3P2	Bit3	X4P4	Bit3	X4P2	Bit4	X5P4	Bit4	X5P2	Bit5	X6P4	Bit5	X6P2	Bit6	X7P4	Bit6	X7P2	Bit7	X8P4	Bit7	X8P2
	Byte	0	Byte	1																																		
Bit0	X1P4	Bit0	X1P2																																			
Bit1	X2P4	Bit1	X2P2																																			
Bit2	X3P4	Bit2	X3P2																																			
Bit3	X4P4	Bit3	X4P2																																			
Bit4	X5P4	Bit4	X5P2																																			
Bit5	X6P4	Bit5	X6P2																																			
Bit6	X7P4	Bit6	X7P2																																			
Bit7	X8P4	Bit7	X8P2																																			



IP67-MT67ML Series Network Module

Order Information				
Interface	Model	Order No.	Description	I/O Connection Type
	MT67ML-EC-DO16P-0.5A	40000289	16 channel output, PNP IP67 Network Module	M12, 5pin Female, A-code
	MT67ML-PN-DO16P-0.5A	40000292		
	MT67ML-EI-DO16P-0.5A	40000296		

Digital Output	
Digital Output	Max. 16
Output Voltage	18...30 VDC
Output Current	0.5A/ch
Diagnosis	point diagnosis
Sync. Factor	1
Switch frequency	250 Hz
Load Type	Resistive, Inductive, Lamp

Module LED					
EtherCat		ProfiNet		EtherNet/IP	
PWR	GN: module power normally				
	RD: module power reverse				
I/O	GN: channel signal normally				
	RD: port power supply short circuit				
LINK	GN: Link normally				
	YE flash: data transmission normally				
	Light off: module unlinked				
RUN	GN: OP status	SF	RD: module fault	MS	GN: module work normally
	GN flash (slowly): SAFEOP status		RD: Internal error		GN flash: unconfigured / unlinked
	GN flash (quickly): Pre-OP status	BF	RD flash: device Name / IP error	NS	RD: device Name / IP error
	light off: Init status				GN: Network normally
ERR	RD flash: communication error				GN flash: Network unlinked
	Light off: module work normally				RD flash: communication error

Pin Definition (I/O port)																																						
	Pins	Address																																				
I/O port	<p>M12(X1~X8) PNP Output</p> <ol style="list-style-type: none"> 1. N/C 2. Output 3. 0 V 4. Output 5. FE 	<table border="1"> <thead> <tr> <th>Byte</th> <th>0</th> <th>Byte</th> <th>1</th> </tr> </thead> <tbody> <tr> <td>Bit0</td> <td>X1P4</td> <td>Bit0</td> <td>X1P2</td> </tr> <tr> <td>Bit1</td> <td>X2P4</td> <td>Bit1</td> <td>X2P2</td> </tr> <tr> <td>Bit2</td> <td>X3P4</td> <td>Bit2</td> <td>X3P2</td> </tr> <tr> <td>Bit3</td> <td>X4P4</td> <td>Bit3</td> <td>X4P2</td> </tr> <tr> <td>Bit4</td> <td>X5P4</td> <td>Bit4</td> <td>X5P2</td> </tr> <tr> <td>Bit5</td> <td>X6P4</td> <td>Bit5</td> <td>X6P2</td> </tr> <tr> <td>Bit6</td> <td>X7P4</td> <td>Bit6</td> <td>X7P2</td> </tr> <tr> <td>Bit7</td> <td>X8P4</td> <td>Bit7</td> <td>X8P2</td> </tr> </tbody> </table>	Byte	0	Byte	1	Bit0	X1P4	Bit0	X1P2	Bit1	X2P4	Bit1	X2P2	Bit2	X3P4	Bit2	X3P2	Bit3	X4P4	Bit3	X4P2	Bit4	X5P4	Bit4	X5P2	Bit5	X6P4	Bit5	X6P2	Bit6	X7P4	Bit6	X7P2	Bit7	X8P4	Bit7	X8P2
Byte	0	Byte	1																																			
Bit0	X1P4	Bit0	X1P2																																			
Bit1	X2P4	Bit1	X2P2																																			
Bit2	X3P4	Bit2	X3P2																																			
Bit3	X4P4	Bit3	X4P2																																			
Bit4	X5P4	Bit4	X5P2																																			
Bit5	X6P4	Bit5	X6P2																																			
Bit6	X7P4	Bit6	X7P2																																			
Bit7	X8P4	Bit7	X8P2																																			
M12 A-code Female																																						



Order Information				
Interface	Model	Order No.	Description	I/O Connection Type
	MT67ML-EC-DO16N-0.5A	40000264	16 channel output, NPN IP67 Network Module	M12, 5pin Female, A-code
	MT67ML-PN-DO16N-0.5A	40000293		
	MT67ML-EI-DO16N-0.5A	40000297		

Digital Output	
Digital Output	Max. 16
Output Voltage	0 VDC
Output Current	0.5A/ch
Diagnosis	point diagnosis
Sync. Factor	1
Switch frequency	250 Hz
Load Type	Resistive, Inductive, Lamp

Module LED					
EtherCat		ProfiNet		EtherNet/IP	
PWR	GN: module power normally				
	RD: module power reverse				
I/O	GN: channel signal normally				
	RD: port power supply short circuit				
LINK	GN: Link normally				
	YE flash: data transmission normally				
	Light off: module unlinked				
RUN	GN: OP status	SF	RD: module fault	MS	GN: module work normally
	GN flash (slowly): SAFEOP status		RD: Internal error		GN flash: unconfigured / unlinked
	GN flash (quickly): Pre-OP status	BF	RD flash: device Name / IP error	NS	RD: device Name / IP error
	light off: Init status		RD flash: device Name / IP error		GN: Network normally
ERR	RD flash: communication error			NS	GN flash: Network unlinked
	Light off: module work normally				RD flash: communication error

Pin Definition (I/O port)																																						
	Pins	Address																																				
I/O port	<p>M12(X1~X8)</p>  <p>NPN</p> <p>Output</p> <ol style="list-style-type: none"> 24VDC+ Output N/C Output FE 	<table border="1"> <thead> <tr> <th>Byte</th> <th>0</th> <th>Byte</th> <th>1</th> </tr> </thead> <tbody> <tr> <td>Bit0</td> <td>X1P4</td> <td>Bit0</td> <td>X1P2</td> </tr> <tr> <td>Bit1</td> <td>X2P4</td> <td>Bit1</td> <td>X2P2</td> </tr> <tr> <td>Bit2</td> <td>X3P4</td> <td>Bit2</td> <td>X3P2</td> </tr> <tr> <td>Bit3</td> <td>X4P4</td> <td>Bit3</td> <td>X4P2</td> </tr> <tr> <td>Bit4</td> <td>X5P4</td> <td>Bit4</td> <td>X5P2</td> </tr> <tr> <td>Bit5</td> <td>X6P4</td> <td>Bit5</td> <td>X6P2</td> </tr> <tr> <td>Bit6</td> <td>X7P4</td> <td>Bit6</td> <td>X7P2</td> </tr> <tr> <td>Bit7</td> <td>X8P4</td> <td>Bit7</td> <td>X8P2</td> </tr> </tbody> </table>	Byte	0	Byte	1	Bit0	X1P4	Bit0	X1P2	Bit1	X2P4	Bit1	X2P2	Bit2	X3P4	Bit2	X3P2	Bit3	X4P4	Bit3	X4P2	Bit4	X5P4	Bit4	X5P2	Bit5	X6P4	Bit5	X6P2	Bit6	X7P4	Bit6	X7P2	Bit7	X8P4	Bit7	X8P2
Byte	0	Byte	1																																			
Bit0	X1P4	Bit0	X1P2																																			
Bit1	X2P4	Bit1	X2P2																																			
Bit2	X3P4	Bit2	X3P2																																			
Bit3	X4P4	Bit3	X4P2																																			
Bit4	X5P4	Bit4	X5P2																																			
Bit5	X6P4	Bit5	X6P2																																			
Bit6	X7P4	Bit6	X7P2																																			
Bit7	X8P4	Bit7	X8P2																																			
M12 A-code Female																																						

IP67-MT67ML Series Network Module



Order Information				
Interface	Model	Order No.	Description	I/O Connection Type
	MT67ML-EC-DI8PDO8P-0.5A	40000290	8 channel input, PNP 8 channel output, PNP IP67 Network Module	M12, 5pin Female, A-code
	MT67ML-PN-DI8PDO8P-0.5A	40000294		
	MT67ML-EI-DI8PDO8P-0.5A	40000298		

Digital Input	
Digital Inputs	Max. 8
Input Type	3-wire PNP sensor or 2-wire passive signal
Input Voltage	11...30 VDC
Diagnosis	Power supply short circuit diagnosis
Switch threshold	EN 61131-2 Type 1/3
Switch frequency	250 Hz
Input delay	20 µs
Max. input current	6 mA

Digital Output	
Digital Output	Max. 8
Output Voltage	18...30 VDC
Output Current	0.5A/ch
Diagnosis	point diagnosis
Sync. Factor	1
Switch frequency	250 Hz
Load Type	Resistive, Inductive, Lamp

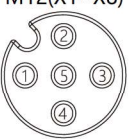
Module LED					
EtherCat		ProfiNet		EtherNet/IP	
PWR	GN: module power normally				
	RD: module power reverse				
I/O	GN: channel signal normally				
	RD: port power supply short circuit				
LINK	GN: Link normally				
	YE flash: data transmission normally				
	Light off: module unlinked				
RUN	GN: OP status	SF	RD: module fault	MS	GN: module work normally
	GN flash (slowly): SAFEOP status		RD: Internal error		GN flash: unconfigured / unlinked
	GN flash (quickly): Pre-OP status	BF	RD flash: device Name / IP error	NS	RD: device Name / IP error
	light off: Init status				GN: Network normally
ERR	RD flash: communication error				GN flash: Network unlinked
	Light off: module work normally				RD flash: communication error

Pin Definition (I/O port)																																																		
I/O port	Pins	Address																																																
	M12 A-code Female	<p>M12(X1~X8)</p>  <table border="0"> <tr> <td style="text-align: center;">PNP Input</td> <td style="text-align: center;">PNP Output</td> </tr> <tr> <td>1. 24 VDC+</td> <td>1. N/C</td> </tr> <tr> <td>2. Input</td> <td>2. Output</td> </tr> <tr> <td>3. 0 V</td> <td>3. 0 V</td> </tr> <tr> <td>4. Input</td> <td>4. Output</td> </tr> <tr> <td>5. FE</td> <td>5. FE</td> </tr> </table>	PNP Input	PNP Output	1. 24 VDC+	1. N/C	2. Input	2. Output	3. 0 V	3. 0 V	4. Input	4. Output	5. FE	5. FE	<table border="1"> <thead> <tr> <th>Byte</th> <th>0</th> <th>Byte</th> <th>1</th> </tr> </thead> <tbody> <tr> <td>Bit0</td> <td>X1P4</td> <td>Bit0</td> <td>X5P4</td> </tr> <tr> <td>Bit1</td> <td>X1P2</td> <td>Bit1</td> <td>X5P2</td> </tr> <tr> <td>Bit2</td> <td>X2P4</td> <td>Bit2</td> <td>X6P4</td> </tr> <tr> <td>Bit3</td> <td>X2P2</td> <td>Bit3</td> <td>X6P2</td> </tr> <tr> <td>Bit4</td> <td>X3P4</td> <td>Bit4</td> <td>X7P4</td> </tr> <tr> <td>Bit5</td> <td>X3P2</td> <td>Bit5</td> <td>X7P2</td> </tr> <tr> <td>Bit6</td> <td>X4P4</td> <td>Bit6</td> <td>X8P4</td> </tr> <tr> <td>Bit7</td> <td>X4P2</td> <td>Bit7</td> <td>X8P2</td> </tr> </tbody> </table>	Byte	0	Byte	1	Bit0	X1P4	Bit0	X5P4	Bit1	X1P2	Bit1	X5P2	Bit2	X2P4	Bit2	X6P4	Bit3	X2P2	Bit3	X6P2	Bit4	X3P4	Bit4	X7P4	Bit5	X3P2	Bit5	X7P2	Bit6	X4P4	Bit6	X8P4	Bit7	X4P2	Bit7
PNP Input	PNP Output																																																	
1. 24 VDC+	1. N/C																																																	
2. Input	2. Output																																																	
3. 0 V	3. 0 V																																																	
4. Input	4. Output																																																	
5. FE	5. FE																																																	
Byte	0	Byte	1																																															
Bit0	X1P4	Bit0	X5P4																																															
Bit1	X1P2	Bit1	X5P2																																															
Bit2	X2P4	Bit2	X6P4																																															
Bit3	X2P2	Bit3	X6P2																																															
Bit4	X3P4	Bit4	X7P4																																															
Bit5	X3P2	Bit5	X7P2																																															
Bit6	X4P4	Bit6	X8P4																																															
Bit7	X4P2	Bit7	X8P2																																															

Order Information				
Interface	Model	Order No.	Description	I/O Connection Type
	MT67ML-EC-DI8NDO8N-0.5A	40000291	8 channel input, NPN 8 channel output, NPN IP67 Network Module	M12, 5pin Female, A-code
	MT67ML-PN-DI8NDO8N-0.5A	40000295		
	MT67ML-EI-DI8NDO8N-0.5A	40000299		

Digital Input	
Digital Inputs	Max. 8
Input Type	3-wire PNP sensor or 2-wire passive signal
Input Voltage	0...5 V
Diagnosis	Power supply short circuit diagnosis
Switch threshold	EN 61131-2 Type 1/3
Switch frequency	250 Hz
Input delay	20 µs
Max. input current	6 mA

Digital Output	
Digital Output	Max. 8
Output Voltage	0 VDC
Output Current	0.5A/ch
Diagnosis	point diagnosis
Sync. Factor	1
Switch frequency	250 Hz
Load Type	Resistive, Inductive, Lamp

Module LED					
EtherCat		ProfiNet		EtherNet/IP	
PWR	GN: module power normally				
	RD: module power reverse				
I/O	GN: channel signal normally				
	RD: port power supply short circuit				
LINK	GN: Link normally				
	YE flash: data transmission normally				
	Light off: module unlinked				
RUN	GN: OP status	SF	RD: module fault	MS	GN: module work normally
	GN flash (slowly): SAFEOP status		RD: Internal error		GN flash: unconfigured / unlinked
	GN flash (quickly): Pre-OP status	BF	RD flash: device Name / IP error	NS	RD: device Name / IP error
	light off: Init status		RD flash: communication error		GN: Network normally
ERR	RD flash: communication error			NS	GN flash: Network unlinked
	Light off: module work normally				RD flash: communication error

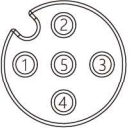
Pin Definition (I/O port)																																						
I/O port	Pins	Address																																				
	M12 A-code Female	<p>M12(X1~X8)</p>  <p>NPN Input</p> <ol style="list-style-type: none"> 24 VDC+ Input 0 V Input FE <p>NPN Output</p> <ol style="list-style-type: none"> 24VDC+ Output N/C Output FE 	<table border="1"> <thead> <tr> <th>Byte</th> <th>0</th> <th>Byte</th> <th>1</th> </tr> </thead> <tbody> <tr> <td>Bit0</td> <td>X1P4</td> <td>Bit0</td> <td>X5P4</td> </tr> <tr> <td>Bit1</td> <td>X1P2</td> <td>Bit1</td> <td>X5P2</td> </tr> <tr> <td>Bit2</td> <td>X2P4</td> <td>Bit2</td> <td>X6P4</td> </tr> <tr> <td>Bit3</td> <td>X2P2</td> <td>Bit3</td> <td>X6P2</td> </tr> <tr> <td>Bit4</td> <td>X3P4</td> <td>Bit4</td> <td>X7P4</td> </tr> <tr> <td>Bit5</td> <td>X3P2</td> <td>Bit5</td> <td>X7P2</td> </tr> <tr> <td>Bit6</td> <td>X4P4</td> <td>Bit6</td> <td>X8P4</td> </tr> <tr> <td>Bit7</td> <td>X4P2</td> <td>Bit7</td> <td>X8P2</td> </tr> </tbody> </table>	Byte	0	Byte	1	Bit0	X1P4	Bit0	X5P4	Bit1	X1P2	Bit1	X5P2	Bit2	X2P4	Bit2	X6P4	Bit3	X2P2	Bit3	X6P2	Bit4	X3P4	Bit4	X7P4	Bit5	X3P2	Bit5	X7P2	Bit6	X4P4	Bit6	X8P4	Bit7	X4P2	Bit7
Byte	0	Byte	1																																			
Bit0	X1P4	Bit0	X5P4																																			
Bit1	X1P2	Bit1	X5P2																																			
Bit2	X2P4	Bit2	X6P4																																			
Bit3	X2P2	Bit3	X6P2																																			
Bit4	X3P4	Bit4	X7P4																																			
Bit5	X3P2	Bit5	X7P2																																			
Bit6	X4P4	Bit6	X8P4																																			
Bit7	X4P2	Bit7	X8P2																																			

IP67-MT67ML Series Network Module



Order Information				
Interface	Model	Order No.	Description	I/O Connection Type
	MT67ML-EC-DIO16P-0.5A	40000237	16 channel, PNP adaptive input/output IP67 Network Module	M12, 5pin Female, A-code
	MT67ML-PN-DIO16P-0.5A	40000121		
	MT67ML-EI-DIO16P-0.5A	40000244		

Digital Input	
Digital Inputs	Max. 16
Input Type	3-wire PNP sensor or 2-wire passive signal
Input Voltage	11...30 VDC
Diagnosis	Power supply short circuit diagnosis
Switch threshold	EN 61131-2 Type 1/3
Switch frequency	250 Hz
Input delay	20 µs
Max. input current	6 mA

Digital Output	
Digital Output	Max. 16
Output Voltage	18...30 VDC
Output Current	0.5A/ch
Diagnosis	point diagnosis
Sync. Factor	1
Switch frequency	250 Hz
Load Type	Resistive, Inductive, Lamp

Module LED					
EtherCat		ProfiNet		EtherNet/IP	
PWR	GN: module power normally				
	RD: module power reverse				
I/O	GN: channel signal normally				
	RD: port power supply short circuit				
LINK	GN: Link normally				
	YE flash: data transmission normally				
	Light off: module unlinked				
RUN	GN: OP status	SF	RD: module fault	MS	GN: module work normally
	GN flash (slowly): SAFEOP status		RD: Internal error		GN flash: unconfigured / unlinked
	GN flash (quickly): Pre-OP status	BF	RD flash: device Name / IP error	NS	RD: device Name / IP error
	light off: Init status		RD flash: device Name / IP error		GN: Network normally
ERR	RD flash: communication error			NS	GN flash: Network unlinked
	Light off: module work normally				RD flash: communication error

Pin Definition (I/O port)																																						
I/O port	Pins	Address																																				
	M12 A-code Female	<p>M12(X1~X8)</p> <p>PNP Input/Output</p> <ol style="list-style-type: none"> 24 VDC+ Input/Output 0 V Input/Output FE 	<table border="1"> <thead> <tr> <th>Byte</th> <th>0</th> <th>Byte</th> <th>1</th> </tr> </thead> <tbody> <tr> <td>Bit0</td> <td>X1P4</td> <td>Bit0</td> <td>X5P4</td> </tr> <tr> <td>Bit1</td> <td>X1P2</td> <td>Bit1</td> <td>X5P2</td> </tr> <tr> <td>Bit2</td> <td>X2P4</td> <td>Bit2</td> <td>X6P4</td> </tr> <tr> <td>Bit3</td> <td>X2P2</td> <td>Bit3</td> <td>X6P2</td> </tr> <tr> <td>Bit4</td> <td>X3P4</td> <td>Bit4</td> <td>X7P4</td> </tr> <tr> <td>Bit5</td> <td>X3P2</td> <td>Bit5</td> <td>X7P2</td> </tr> <tr> <td>Bit6</td> <td>X4P4</td> <td>Bit6</td> <td>X8P4</td> </tr> <tr> <td>Bit7</td> <td>X4P2</td> <td>Bit7</td> <td>X8P2</td> </tr> </tbody> </table>	Byte	0	Byte	1	Bit0	X1P4	Bit0	X5P4	Bit1	X1P2	Bit1	X5P2	Bit2	X2P4	Bit2	X6P4	Bit3	X2P2	Bit3	X6P2	Bit4	X3P4	Bit4	X7P4	Bit5	X3P2	Bit5	X7P2	Bit6	X4P4	Bit6	X8P4	Bit7	X4P2	Bit7
Byte	0	Byte	1																																			
Bit0	X1P4	Bit0	X5P4																																			
Bit1	X1P2	Bit1	X5P2																																			
Bit2	X2P4	Bit2	X6P4																																			
Bit3	X2P2	Bit3	X6P2																																			
Bit4	X3P4	Bit4	X7P4																																			
Bit5	X3P2	Bit5	X7P2																																			
Bit6	X4P4	Bit6	X8P4																																			
Bit7	X4P2	Bit7	X8P2																																			

Order Information				
Interface	Model	Order No.	Description	I/O Connection Type
	MT67ML-EC-DIO16N-0.5A	40000229	16 channel,NPN adaptive input/output IP67 Network Module	M12, 5pin Female, A-code
	MT67ML-PN-DIO16N-0.5A	40000120		
	MT67ML-EI-DIO16N-0.5A	40000245		



Digital Input	
Digital Inputs	Max. 16
Input Type	3-wire PNP sensor or 2-wire passive signal
Input Voltage	0...5 V
Diagnosis	Power supply short circuit diagnosis
Switch threshold	EN 61131-2 Type 1/3
Switch frequency	250 Hz
Input delay	20 µs
Max. input current	6 mA

Digital Output	
Digital Output	Max. 16
Output Voltage	0 VDC
Output Current	0.5A/ch
Diagnosis	point diagnosis
Sync. Factor	1
Switch frequency	250 Hz
Load Type	Resistive, Inductive, Lamp

Module LED					
EtherCat		ProfiNet		EtherNet/IP	
PWR	GN: module power normally				
	RD: module power reverse				
I/O	GN: channel signal normally				
	RD: port power supply short circuit				
LINK	GN: Link normally				
	YE flash: data transmission normally				
	Light off: module unlinked				
RUN	GN: OP status	SF	RD: module fault	MS	GN: module work normally
	GN flash (slowly): SAFEOP status		RD: Internal error		GN flash: unconfigured / unlinked
	GN flash (quickly): Pre-OP status	BF	RD flash: device Name / IP error	NS	RD: device Name / IP error
	Light off: Init status		RD flash: communication error		GN: Network normally
ERR	RD flash: communication error			NS	GN flash: Network unlinked
	Light off: module work normally				RD flash: communication error

Pin Definition (I/O port)																																						
I/O port	Pins	Address																																				
	M12 A-code Female	<p>M12(X1~X8)</p>  <p>NPN Input/Output</p> <ol style="list-style-type: none"> 24 VDC+ Input/Output 0 V Input/Output FE 	<table border="1"> <thead> <tr> <th>Byte</th> <th>0</th> <th>Byte</th> <th>1</th> </tr> </thead> <tbody> <tr> <td>Bit0</td> <td>X1P4</td> <td>Bit0</td> <td>X5P4</td> </tr> <tr> <td>Bit1</td> <td>X1P2</td> <td>Bit1</td> <td>X5P2</td> </tr> <tr> <td>Bit2</td> <td>X2P4</td> <td>Bit2</td> <td>X6P4</td> </tr> <tr> <td>Bit3</td> <td>X2P2</td> <td>Bit3</td> <td>X6P2</td> </tr> <tr> <td>Bit4</td> <td>X3P4</td> <td>Bit4</td> <td>X7P4</td> </tr> <tr> <td>Bit5</td> <td>X3P2</td> <td>Bit5</td> <td>X7P2</td> </tr> <tr> <td>Bit6</td> <td>X4P4</td> <td>Bit6</td> <td>X8P4</td> </tr> <tr> <td>Bit7</td> <td>X4P2</td> <td>Bit7</td> <td>X8P2</td> </tr> </tbody> </table>	Byte	0	Byte	1	Bit0	X1P4	Bit0	X5P4	Bit1	X1P2	Bit1	X5P2	Bit2	X2P4	Bit2	X6P4	Bit3	X2P2	Bit3	X6P2	Bit4	X3P4	Bit4	X7P4	Bit5	X3P2	Bit5	X7P2	Bit6	X4P4	Bit6	X8P4	Bit7	X4P2	Bit7
Byte	0	Byte	1																																			
Bit0	X1P4	Bit0	X5P4																																			
Bit1	X1P2	Bit1	X5P2																																			
Bit2	X2P4	Bit2	X6P4																																			
Bit3	X2P2	Bit3	X6P2																																			
Bit4	X3P4	Bit4	X7P4																																			
Bit5	X3P2	Bit5	X7P2																																			
Bit6	X4P4	Bit6	X8P4																																			
Bit7	X4P2	Bit7	X8P2																																			



IP67-MT67ML Series Network Module

Order Information				
Interface	Model	Order No.	Description	I/O Connection Type
	MT67ML-EC-DO16P-2A	40000038	16 channel output, PNP IP67 Network Module	M12, 5pin Female, A-code
	MT67ML-PN-DO16P-2A	40000130		
	MT67ML-EI-DO16P-2A	40000018		

Digital Output	
Digital Output	Max. 16
Output Voltage	18...30 VDC
Output Current	2A/ch
Diagnosis	point diagnosis
Sync. Factor	1
Switch frequency	250 Hz
Load Type	Resistive, Inductive, Lamp

Module LED					
EtherCat		ProfiNet		EtherNet/IP	
PWR	GN: module power normally				
	RD: module power reverse				
I/O	GN: channel signal normally				
	RD: port power supply short circuit				
LINK	GN: Link normally				
	YE flash: data transmission normally				
	Light off: module unlinked				
RUN	GN: OP status	SF	RD: module fault	MS	GN: module work normally
	GN flash (slowly): SAFEOP status		RD: Internal error		GN flash: unconfigured / unlinked
	GN flash (quickly): Pre-OP status	BF	RD flash: device Name / IP error	NS	RD: device Name / IP error
	light off: Init status		RD flash: device Name / IP error		GN: Network normally
ERR	RD flash: communication error			NS	GN flash: Network unlinked
	Light off: module work normally				RD flash: communication error

Pin Definition (I/O port)																																						
I/O port	Pins	Address																																				
	M12 A-code Female	<p>M12(X1~X8)</p>  <p>PNP</p> <p>Output</p> <ol style="list-style-type: none"> N/C Output 0 V Output FE 	<table border="1"> <thead> <tr> <th>Byte</th> <th>0</th> <th>Byte</th> <th>1</th> </tr> </thead> <tbody> <tr> <td>Bit0</td> <td>X1P4</td> <td>Bit0</td> <td>X1P2</td> </tr> <tr> <td>Bit1</td> <td>X2P4</td> <td>Bit1</td> <td>X2P2</td> </tr> <tr> <td>Bit2</td> <td>X3P4</td> <td>Bit2</td> <td>X3P2</td> </tr> <tr> <td>Bit3</td> <td>X4P4</td> <td>Bit3</td> <td>X4P2</td> </tr> <tr> <td>Bit4</td> <td>X5P4</td> <td>Bit4</td> <td>X5P2</td> </tr> <tr> <td>Bit5</td> <td>X6P4</td> <td>Bit5</td> <td>X6P2</td> </tr> <tr> <td>Bit6</td> <td>X7P4</td> <td>Bit6</td> <td>X7P2</td> </tr> <tr> <td>Bit7</td> <td>X8P4</td> <td>Bit7</td> <td>X8P2</td> </tr> </tbody> </table>	Byte	0	Byte	1	Bit0	X1P4	Bit0	X1P2	Bit1	X2P4	Bit1	X2P2	Bit2	X3P4	Bit2	X3P2	Bit3	X4P4	Bit3	X4P2	Bit4	X5P4	Bit4	X5P2	Bit5	X6P4	Bit5	X6P2	Bit6	X7P4	Bit6	X7P2	Bit7	X8P4	Bit7
Byte	0	Byte	1																																			
Bit0	X1P4	Bit0	X1P2																																			
Bit1	X2P4	Bit1	X2P2																																			
Bit2	X3P4	Bit2	X3P2																																			
Bit3	X4P4	Bit3	X4P2																																			
Bit4	X5P4	Bit4	X5P2																																			
Bit5	X6P4	Bit5	X6P2																																			
Bit6	X7P4	Bit6	X7P2																																			
Bit7	X8P4	Bit7	X8P2																																			

Order Information				
Interface	Model	Order No.	Description	I/O Connection Type
	MT67ML-EC-DI8PDO8P-2A	40000039	8 channel input, PNP 8 channel output, PNP IP67 Network Module	M12, 5pin Female, A-code
	MT67ML-PN-DI8PDO8P-2A	40000125		
	MT67ML-EI-DI8PDO8P-2A	40000013		

Digital Input	
Digital Inputs	Max. 8
Input Type	3-wire PNP sensor or 2-wire passive signal
Input Voltage	11...30 VDC
Diagnosis	Power supply short circuit diagnosis
Switch threshold	EN 61131-2 Type 1/3
Switch frequency	250 Hz
Input delay	≤250 Hz
Max. input current	6 mA

Digital Output	
Digital Output	Max. 8
Output Voltage	18...30 VDC
Output Current	0.5A/ch
Diagnosis	point diagnosis
Sync. Factor	1
Switch frequency	250 Hz
Load Type	Resistive, Inductive, Lamp

Module LED					
EtherCat		ProfiNet		EtherNet/IP	
PWR	GN: module power normally				
	RD: module power reverse				
I/O	GN: channel signal normally				
	RD: port power supply short circuit				
LINK	GN: Link normally				
	YE flash: data transmission normally				
	Light off: module unlinked				
RUN	GN: OP status	SF	RD: module fault	MS	GN: module work normally
	GN flash (slowly): SAFEOP status		RD: Internal error		GN flash: unconfigured / unlinked
	GN flash (quickly): Pre-OP status	BF	RD flash: device Name / IP error	NS	RD: device Name / IP error
	light off: Init status				GN: Network normally
ERR	RD flash: communication error				GN flash: Network unlinked
	Light off: module work normally				RD flash: communication error

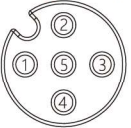
Pin Definition (I/O port)																																																		
I/O port	Pins	Address																																																
	M12 A-code Female	<p>M12(X1~X8)</p>  <table border="0"> <tr> <td style="text-align: center;">PNP Input</td> <td style="text-align: center;">PNP Output</td> </tr> <tr> <td>1. 24 VDC+</td> <td>1. N/C</td> </tr> <tr> <td>2. Input</td> <td>2. Output</td> </tr> <tr> <td>3. 0 V</td> <td>3. 0 V</td> </tr> <tr> <td>4. Input</td> <td>4. Output</td> </tr> <tr> <td>5. FE</td> <td>5. FE</td> </tr> </table>	PNP Input	PNP Output	1. 24 VDC+	1. N/C	2. Input	2. Output	3. 0 V	3. 0 V	4. Input	4. Output	5. FE	5. FE	<table border="1"> <thead> <tr> <th>Byte</th> <th>0</th> <th>Byte</th> <th>1</th> </tr> </thead> <tbody> <tr> <td>Bit0</td> <td>X1P4</td> <td>Bit0</td> <td>X5P4</td> </tr> <tr> <td>Bit1</td> <td>X1P2</td> <td>Bit1</td> <td>X5P2</td> </tr> <tr> <td>Bit2</td> <td>X2P4</td> <td>Bit2</td> <td>X6P4</td> </tr> <tr> <td>Bit3</td> <td>X2P2</td> <td>Bit3</td> <td>X6P2</td> </tr> <tr> <td>Bit4</td> <td>X3P4</td> <td>Bit4</td> <td>X7P4</td> </tr> <tr> <td>Bit5</td> <td>X3P2</td> <td>Bit5</td> <td>X7P2</td> </tr> <tr> <td>Bit6</td> <td>X4P4</td> <td>Bit6</td> <td>X8P4</td> </tr> <tr> <td>Bit7</td> <td>X4P2</td> <td>Bit7</td> <td>X8P2</td> </tr> </tbody> </table>	Byte	0	Byte	1	Bit0	X1P4	Bit0	X5P4	Bit1	X1P2	Bit1	X5P2	Bit2	X2P4	Bit2	X6P4	Bit3	X2P2	Bit3	X6P2	Bit4	X3P4	Bit4	X7P4	Bit5	X3P2	Bit5	X7P2	Bit6	X4P4	Bit6	X8P4	Bit7	X4P2	Bit7
PNP Input	PNP Output																																																	
1. 24 VDC+	1. N/C																																																	
2. Input	2. Output																																																	
3. 0 V	3. 0 V																																																	
4. Input	4. Output																																																	
5. FE	5. FE																																																	
Byte	0	Byte	1																																															
Bit0	X1P4	Bit0	X5P4																																															
Bit1	X1P2	Bit1	X5P2																																															
Bit2	X2P4	Bit2	X6P4																																															
Bit3	X2P2	Bit3	X6P2																																															
Bit4	X3P4	Bit4	X7P4																																															
Bit5	X3P2	Bit5	X7P2																																															
Bit6	X4P4	Bit6	X8P4																																															
Bit7	X4P2	Bit7	X8P2																																															

IP67-MT67ML Series Network Module

Order Information				
Interface	Model	Order No.	Description	I/O Connection Type
	MT67ML-EC-DIO16P-2A	40000037	16 channel, PNP adaptive input/output IP67 Network Module	M12, 5pin Female, A-code
	MT67ML-PN-DIO16P-2A	40000124		
	MT67ML-EI-DIO16P-2A	40000012		

Digital Input	
Digital Inputs	Max. 16
Input Type	3-wire PNP sensor or 2-wire passive signal
Input Voltage	11...30 VDC
Diagnosis	Power supply short circuit diagnosis
Switch threshold	EN 61131-2 Type 1/3
Switch frequency	250 Hz
Input delay	≤250 Hz
Max. input current	6 mA

Digital Output	
Digital Output	Max. 16
Output Voltage	18...30 VDC
Output Current	0.5A/ch
Diagnosis	point diagnosis
Sync. Factor	1
Switch frequency	250 Hz
Load Type	Resistive, Inductive, Lamp

Module LED					
EtherCat		ProfiNet		EtherNet/IP	
PWR	GN: module power normally				
	RD: module power reverse				
I/O	GN: channel signal normally				
	RD: port power supply short circuit				
LINK	GN: Link normally				
	YE flash: data transmission normally				
	Light off: module unlinked				
RUN	GN: OP status	SF	RD: module fault	MS	GN: module work normally
	GN flash (slowly): SAFEOP status		RD: Internal error		GN flash: unconfigured / unlinked
	GN flash (quickly): Pre-OP status	BF	RD flash: device Name / IP error	NS	RD: device Name / IP error
	light off: Init status		RD flash: communication error		GN: Network normally
ERR	RD flash: communication error			NS	GN flash: Network unlinked
	Light off: module work normally				RD flash: communication error

Pin Definition (I/O port)																																						
I/O port	Pins	Address																																				
	M12 A-code Female	<p>M12(X1~X8)</p> <p>PNP Input/Output</p> <ol style="list-style-type: none"> 24 VDC+ Input/Output 0 V Input/Output FE 	<table border="1"> <thead> <tr> <th>Byte</th> <th>0</th> <th>Byte</th> <th>1</th> </tr> </thead> <tbody> <tr> <td>Bit0</td> <td>X1P4</td> <td>Bit0</td> <td>X5P4</td> </tr> <tr> <td>Bit1</td> <td>X1P2</td> <td>Bit1</td> <td>X5P2</td> </tr> <tr> <td>Bit2</td> <td>X2P4</td> <td>Bit2</td> <td>X6P4</td> </tr> <tr> <td>Bit3</td> <td>X2P2</td> <td>Bit3</td> <td>X6P2</td> </tr> <tr> <td>Bit4</td> <td>X3P4</td> <td>Bit4</td> <td>X7P4</td> </tr> <tr> <td>Bit5</td> <td>X3P2</td> <td>Bit5</td> <td>X7P2</td> </tr> <tr> <td>Bit6</td> <td>X4P4</td> <td>Bit6</td> <td>X8P4</td> </tr> <tr> <td>Bit7</td> <td>X4P2</td> <td>Bit7</td> <td>X8P2</td> </tr> </tbody> </table>	Byte	0	Byte	1	Bit0	X1P4	Bit0	X5P4	Bit1	X1P2	Bit1	X5P2	Bit2	X2P4	Bit2	X6P4	Bit3	X2P2	Bit3	X6P2	Bit4	X3P4	Bit4	X7P4	Bit5	X3P2	Bit5	X7P2	Bit6	X4P4	Bit6	X8P4	Bit7	X4P2	Bit7
Byte	0	Byte	1																																			
Bit0	X1P4	Bit0	X5P4																																			
Bit1	X1P2	Bit1	X5P2																																			
Bit2	X2P4	Bit2	X6P4																																			
Bit3	X2P2	Bit3	X6P2																																			
Bit4	X3P4	Bit4	X7P4																																			
Bit5	X3P2	Bit5	X7P2																																			
Bit6	X4P4	Bit6	X8P4																																			
Bit7	X4P2	Bit7	X8P2																																			



**IP67-MT67MC-M12
Network Module**

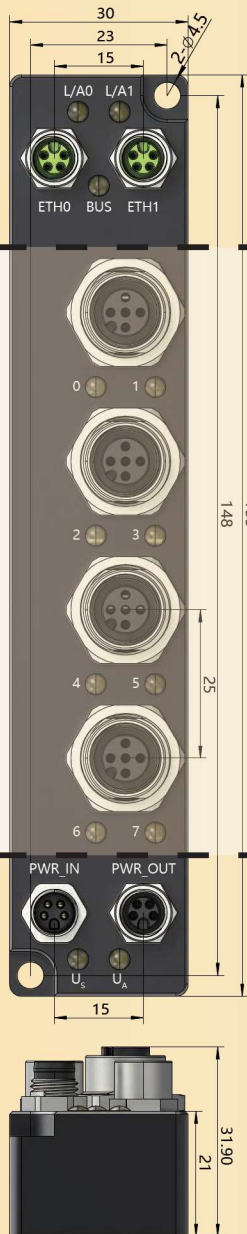

Pin Definition (Data Port)			
M8 A-code Female	Connection Type	2 x M8 D-code; 4-pin Female	ETH0 , ETH1 1. TX+ 2. RX+ 3. TX- 4. RX-
	Physical layer	Ethernet	
	Transfer rate	10/100 Mbps, full duplex	
	Characteristic	Compliant with the protocol	
	Alarm function	Diagnostic&process alarms	
	Min. Cycle Time	250 μs	
	Port fixed torque	M8:0.5Nm	

Basic parameters	
Housing material	Aluminum alloy
Housing color	Anodized black
Protection level	IP67 , epoxy full potting
Dimensions (W x H x D)	155mm x 30mm x 31.9mm
Weight	208g
Operating temperature	-25°C...70°C
Storage temperature	-40°C...85°C
Operating humidity	5%...95%
Storage humidity	5%...95%
Operating Atmospheric pressure	80KPa...106KPa
Storage Atmospheric pressure	80KPa...106KPa
Tightening torque (IO)	M8:0.5Nm
Application Environment	According to EN-61131
Vibration Test	According to IEC60068-2
Impact Test	According to IEC60068-27
Free Drop Test	According to IEC60068-32
EMC	According to IEC61000-4-2;-3,-4
Certification	CE,RoHS
Mounting Hole size	Φ4.5mm x 2



Pin Definition (Power Port)			
Power Supply Port	System voltage Us	18...30 VDC (type.24VDC)	PWR_IN PWR_OUT Male Female 1. +24V_Us 2. +24V_Ua 3. GND_Us 4. GND_Ua
	Auxiliary voltage Ua	18...30 VDC (type.24VDC)	
	Current sum Is	4A	
	Current sum Ia	4A	
	No-load current Ic	≤150mA	
	Reverse power protection	Yes	
M8 A-code Female& Male	Tightening torque (Power)	M8:0.5Nm	

Order Information				
Interface	Model	Order No.	Description	I/O Connection Type
	MT67MC-EC-DI8P-M12	40000026	8 channel input, PNP IP67 Network Module	M12, 5pin Female, A-code
	MT67MC-PN-DI8P-M12	40000062		
	MT67MC-EI-DI8P-M12	40000158		

Digital Input	
Digital Inputs	Max. 8
Input Type	3-wire PNP sensor or 2-wire passive signal
Input Voltage	11...30 VDC
Diagnosis	Power supply short circuit diagnosis
Switch threshold	EN 61131-2 Type 1/3
Switch frequency	250 Hz
Input delay	20 µs
Max. input current	6 mA

Module LED					
EtherCat		ProfiNet		EtherNet/IP	
PWR			GN: module power normally		
			RD: module power reverse		
L/A0 L/A1			GN: channel signal normally		
			GN flash: extended communication normally		
I/O			GN: channel signal normally		
			RD: port power supply short circuit		
BUS	GN: OP status	BUS	Off: module work normally	BUS	GN: module work normally
	GN flash (slowly): SAFEOP status		RD: module work abnormally		GN flash: unconfigured / unlinked
	GN flash (quickly): Pre-OP status		RD flash: device Name / IP error		RD flash: device Name / IP error
	light off: Init status				
	RD&GN flash: communication error				

Pin Definition (I/O port)																				
	Pins	Address																		
I/O port	<p>M12(X1~X4)</p> <p>PNP</p> <p>Input</p> <p>1. 24 VDC+</p> <p>2. Input</p> <p>3. 0 V</p> <p>4. Input</p> <p>5. FE</p>	<table border="1"> <thead> <tr> <th>Byte</th> <th>0</th> </tr> </thead> <tbody> <tr> <td>Bit0</td> <td>X1P4</td> </tr> <tr> <td>Bit1</td> <td>X1P2</td> </tr> <tr> <td>Bit2</td> <td>X2P4</td> </tr> <tr> <td>Bit3</td> <td>X2P2</td> </tr> <tr> <td>Bit4</td> <td>X3P4</td> </tr> <tr> <td>Bit5</td> <td>X3P2</td> </tr> <tr> <td>Bit6</td> <td>X4P4</td> </tr> <tr> <td>Bit7</td> <td>X4P2</td> </tr> </tbody> </table>	Byte	0	Bit0	X1P4	Bit1	X1P2	Bit2	X2P4	Bit3	X2P2	Bit4	X3P4	Bit5	X3P2	Bit6	X4P4	Bit7	X4P2
Byte	0																			
Bit0	X1P4																			
Bit1	X1P2																			
Bit2	X2P4																			
Bit3	X2P2																			
Bit4	X3P4																			
Bit5	X3P2																			
Bit6	X4P4																			
Bit7	X4P2																			
M12 A-code Female																				

Order Information				
Interface	Model	Order No.	Description	I/O Connection Type
	MT67MC-EC-DI8N-M12	40000029	8 channel input, NPN IP67 Network Module	M12, 5pin Female, A-code
	MT67MC-PN-DI8N-M12	40000063		
	MT67MC-EI-DI8N-M12	40000159		

Digital Input	
Digital Inputs	Max. 8
Input Type	3-wire PNP sensor or 2-wire passive signal
Input Voltage	0...5 VDC
Diagnosis	Power supply short circuit diagnosis
Switch threshold	EN 61131-2 Type 1/3
Switch frequency	250 Hz
Input delay	20 µs
Max. input current	6 mA

Module LED					
EtherCat		ProfiNet		EtherNet/IP	
PWR	GN: module power normally				
	RD: module power reverse				
L/A0 L/A1	GN: channel signal normally				
	GN flash: extended communication normally				
I/O	GN: channel signal normally				
	RD: port power supply short circuit				
BUS	GN: OP status	BUS	Off: module work normally	BUS	GN: module work normally
	GN flash (slowly): SAFEOP status		RD: module work abnormally		GN flash: unconfigured / unlinked
	GN flash (quickly): Pre-OP status		RD flash: device Name / IP error		RD flash: device Name / IP error
	light off: Init status				
	RD&GN flash: communication error				

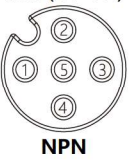

Pin Definition (I/O port)																				
	Pins	Address																		
I/O port	M12(X1~X4)	<table border="1"> <thead> <tr> <th>Byte</th> <th>0</th> </tr> </thead> <tbody> <tr> <td>Bit0</td> <td>X1P4</td> </tr> <tr> <td>Bit1</td> <td>X1P2</td> </tr> <tr> <td>Bit2</td> <td>X2P4</td> </tr> <tr> <td>Bit3</td> <td>X2P2</td> </tr> <tr> <td>Bit4</td> <td>X3P4</td> </tr> <tr> <td>Bit5</td> <td>X3P2</td> </tr> <tr> <td>Bit6</td> <td>X4P4</td> </tr> <tr> <td>Bit7</td> <td>X4P2</td> </tr> </tbody> </table>	Byte	0	Bit0	X1P4	Bit1	X1P2	Bit2	X2P4	Bit3	X2P2	Bit4	X3P4	Bit5	X3P2	Bit6	X4P4	Bit7	X4P2
	Byte		0																	
Bit0	X1P4																			
Bit1	X1P2																			
Bit2	X2P4																			
Bit3	X2P2																			
Bit4	X3P4																			
Bit5	X3P2																			
Bit6	X4P4																			
Bit7	X4P2																			
M12 A-code Female	 <p>Input</p> <ol style="list-style-type: none"> 24 VDC+ Input 0 V Input FE 																			

Order Information				
Interface	Model	Order No.	Description	I/O Connection Type
	MT67MC-EC-DO8P-M12-0.5A	40000027	8 channel output, PNP IP67 Network Module	M12, 5pin Female, A-code
	MT67MC-PN-DO8P-M12-0.5A	40000066		
	MT67MC-EI-DO8P-M12-0.5A	40000162		

Digital Output	
Digital Output	Max. 8
Output Voltage	18...30 VDC
Output Current	0.5A/ch
Diagnosis	point diagnosis
Sync. Factor	1
Switch frequency	250 Hz
Load Type	Resistive, Inductive, Lamp

Module LED					
EtherCat		ProfiNet		EtherNet/IP	
PWR			GN: module power normally		
			RD: module power reverse		
L/A0 L/A1			GN: channel signal normally		
			GN flash: extended communication normally		
I/O			GN: channel signal normally		
			RD: port power supply short circuit		
BUS	GN: OP status	BUS	Off: module work normally	BUS	GN: module work normally
	GN flash (slowly): SAFEOP status		RD: module work abnormally		GN flash: unconfigured / unlinked
	GN flash (quickly): Pre-OP status		RD flash: device Name / IP error		RD flash: device Name / IP error
	light off: Init status				
	RD&GN flash: communication error				

Pin Definition (I/O port)																				
	Pins	Address																		
I/O port	<p>M12(X1~X4)</p> <p>PNP</p> <p>Output</p> <ol style="list-style-type: none"> N/C Output 0 V Output FE 	<table border="1"> <thead> <tr> <th>Byte</th> <th>0</th> </tr> </thead> <tbody> <tr> <td>Bit0</td> <td>X1P4</td> </tr> <tr> <td>Bit1</td> <td>X1P2</td> </tr> <tr> <td>Bit2</td> <td>X2P4</td> </tr> <tr> <td>Bit3</td> <td>X2P2</td> </tr> <tr> <td>Bit4</td> <td>X3P4</td> </tr> <tr> <td>Bit5</td> <td>X3P2</td> </tr> <tr> <td>Bit6</td> <td>X4P4</td> </tr> <tr> <td>Bit7</td> <td>X4P2</td> </tr> </tbody> </table>	Byte	0	Bit0	X1P4	Bit1	X1P2	Bit2	X2P4	Bit3	X2P2	Bit4	X3P4	Bit5	X3P2	Bit6	X4P4	Bit7	X4P2
Byte	0																			
Bit0	X1P4																			
Bit1	X1P2																			
Bit2	X2P4																			
Bit3	X2P2																			
Bit4	X3P4																			
Bit5	X3P2																			
Bit6	X4P4																			
Bit7	X4P2																			
M12 A-code Female																				

Order Information				
Interface	Model	Order No.	Description	I/O Connection Type
	MT67MC-EC-DO8N-M12-0.5A	40000043	8 channel output, NPN IP67 Network Module	M12, 5pin Female, A-code
	MT67MC-PN-DO8N-M12-0.5A	40000070		
	MT67MC-EI-DO8N-M12-0.5A	40000153		

Digital Output	
Digital Output	Max. 8
Output Voltage	0 VDC
Output Current	0.5A/ch
Diagnosis	point diagnosis
Sync. Factor	1
Switch frequency	250 Hz
Load Type	Resistive, Inductive, Lamp

Module LED					
EtherCat		ProfiNet		EtherNet/IP	
PWR			GN: module power normally		
			RD: module power reverse		
L/A0 L/A1			GN: channel signal normally		
			GN flash: extended communication normally		
I/O			GN: channel signal normally		
			RD: port power supply short circuit		
BUS	GN: OP status	BUS	Off: module work normally	BUS	GN: module work normally
	GN flash (slowly): SAFEOP status		RD: module work abnormally		GN flash: unconfigured / unlinked
	GN flash (quickly): Pre-OP status		RD flash: device Name / IP error		RD flash: device Name / IP error
	light off: Init status				
	RD&GN flash: communication error				

Pin Definition (I/O port)																				
	Pins	Address																		
I/O port	<p>M12(X1~X4)</p>  <p>NPN</p> <p>Output</p> <p>1. 24VDC+ 2. Output 3. N/C 4. Output 5. FE</p>	<table border="1"> <thead> <tr> <th>Byte</th> <th>0</th> </tr> </thead> <tbody> <tr> <td>Bit0</td> <td>X1P4</td> </tr> <tr> <td>Bit1</td> <td>X1P2</td> </tr> <tr> <td>Bit2</td> <td>X2P4</td> </tr> <tr> <td>Bit3</td> <td>X2P2</td> </tr> <tr> <td>Bit4</td> <td>X3P4</td> </tr> <tr> <td>Bit5</td> <td>X3P2</td> </tr> <tr> <td>Bit6</td> <td>X4P4</td> </tr> <tr> <td>Bit7</td> <td>X4P2</td> </tr> </tbody> </table>	Byte	0	Bit0	X1P4	Bit1	X1P2	Bit2	X2P4	Bit3	X2P2	Bit4	X3P4	Bit5	X3P2	Bit6	X4P4	Bit7	X4P2
Byte	0																			
Bit0	X1P4																			
Bit1	X1P2																			
Bit2	X2P4																			
Bit3	X2P2																			
Bit4	X3P4																			
Bit5	X3P2																			
Bit6	X4P4																			
Bit7	X4P2																			
M12 A-code Female																				



Order Information				
Interface	Model	Order No.	Description	I/O Connection Type
	MT67MC-EC-DIO8P-M12-0.5A	40000028	16 channel, PNP adaptive input/output IP67 Network Module	M12, 5pin Female, A-code
	MT67MC-PN-DIO8P-M12-0.5A	40000072		
	MT67MC-EI-DIO8P-M12-0.5A	40000161		

Digital Input	
Digital Inputs	Max. 8
Input Signal	3-wire PNP sensor or 2-wire passive signal
Input Voltage	11...30 VDC
Diagnosis	Power supply short circuit diagnosis
Switch threshold	EN 61131-2 Type 1/3
Switch frequency	250 Hz
Input delay	20 µs
Max. input current	6 mA

Digital Output	
Digital Output	Max. 8
Output Voltage	18...30 VDC
Output Current	0.5A/ch
Diagnosis	point diagnosis
Sync. Factor	1
Switch frequency	250 Hz
Load Type	Resistive, Inductive, Lamp

Module LED				
EtherCat		ProfiNet		EtherNet/IP
PWR	GN: module power normally			
	RD: module power reverse			
L/A0 L/A1	GN: channel signal normally			
	GN flash: extended communication normally			
I/O	GN: channel signal normally			
	RD: port power supply short circuit			
BUS	GN: OP status	BUS	Off: module work normally	BUS
	GN flash (slowly): SAFEOP status		RD: module work abnormally	
	GN flash (quickly): Pre-OP status		RD flash: device Name / IP error	
	light off: Init status			
	RD&GN flash: communication error			
				GN: module work normally
				GN flash: unconfigured / unlinked
				RD flash: device Name / IP error

Pin Definition (I/O port)																				
	Pins	Address																		
I/O port	<p>M12(X1~X4)</p> <p>PNP Input/Output</p> <ol style="list-style-type: none"> 24 VDC+ Input/Output 0 V Input/Output FE 	<table border="1"> <thead> <tr> <th>Byte</th> <th>0</th> </tr> </thead> <tbody> <tr> <td>Bit0</td> <td>X1P4</td> </tr> <tr> <td>Bit1</td> <td>X1P2</td> </tr> <tr> <td>Bit2</td> <td>X2P4</td> </tr> <tr> <td>Bit3</td> <td>X2P2</td> </tr> <tr> <td>Bit4</td> <td>X3P4</td> </tr> <tr> <td>Bit5</td> <td>X3P2</td> </tr> <tr> <td>Bit6</td> <td>X4P4</td> </tr> <tr> <td>Bit7</td> <td>X4P2</td> </tr> </tbody> </table>	Byte	0	Bit0	X1P4	Bit1	X1P2	Bit2	X2P4	Bit3	X2P2	Bit4	X3P4	Bit5	X3P2	Bit6	X4P4	Bit7	X4P2
Byte	0																			
Bit0	X1P4																			
Bit1	X1P2																			
Bit2	X2P4																			
Bit3	X2P2																			
Bit4	X3P4																			
Bit5	X3P2																			
Bit6	X4P4																			
Bit7	X4P2																			
M12 A-code Female																				

Order Information				
Interface	Model	Order No.	Description	I/O Connection Type
	MT67MC-EC-DIO8N-M12-0.5A	40000044	16 channel,NPN adaptive input/output IP67 Network Module	M12, 5pin Female, A-code
	MT67MC-PN-DIO8N-M12-0.5A	40000073		
	MT67MC-EI-DIO8N-M12-0.5A	40000033		

Digital Input	
Digital Inputs	Max. 8
Input Signal	3-wire PNP sensor or 2-wire passive signal
Input Voltage	0...5 VDC
Diagnosis	Power supply short circuit diagnosis
Switch threshold	EN 61131-2 Type 1/3
Switch frequency	250 Hz
Input delay	20 µs
Max. input current	6 mA

Digital Output	
Digital Output	Max. 8
Output Voltage	0 VDC
Output Current	0.5A/ch
Diagnosis	point diagnosis
Sync. Factor	1
Switch frequency	250 Hz
Load Type	Resistive, Inductive, Lamp

Module LED				
EtherCat		ProfiNet		EtherNet/IP
PWR	GN: module power normally			
	RD: module power reverse			
L/A0 L/A1	GN: channel signal normally			
	GN flash: extended communication normally			
I/O	GN: channel signal normally			
	RD: port power supply short circuit			
BUS	GN: OP status	BUS	Off: module work normally	BUS
	GN flash (slowly): SAFEOP status		RD: module work abnormally	
	GN flash (quickly): Pre-OP status		RD flash: device Name / IP error	
	light off: Init status			
	RD&GN flash: communication error			
				GN: module work normally
				GN flash: unconfigured / unlinked
				RD flash: device Name / IP error

Pin Definition (I/O port)																				
	Pins	Address																		
I/O port	M12(X1~X4)	<table border="1"> <thead> <tr> <th>Byte</th> <th>0</th> </tr> </thead> <tbody> <tr> <td>Bit0</td> <td>X1P4</td> </tr> <tr> <td>Bit1</td> <td>X1P2</td> </tr> <tr> <td>Bit2</td> <td>X2P4</td> </tr> <tr> <td>Bit3</td> <td>X2P2</td> </tr> <tr> <td>Bit4</td> <td>X3P4</td> </tr> <tr> <td>Bit5</td> <td>X3P2</td> </tr> <tr> <td>Bit6</td> <td>X4P4</td> </tr> <tr> <td>Bit7</td> <td>X4P2</td> </tr> </tbody> </table>	Byte	0	Bit0	X1P4	Bit1	X1P2	Bit2	X2P4	Bit3	X2P2	Bit4	X3P4	Bit5	X3P2	Bit6	X4P4	Bit7	X4P2
	Byte		0																	
Bit0	X1P4																			
Bit1	X1P2																			
Bit2	X2P4																			
Bit3	X2P2																			
Bit4	X3P4																			
Bit5	X3P2																			
Bit6	X4P4																			
Bit7	X4P2																			
M12 A-code Female	 <p>NPN Input/Output</p> <ol style="list-style-type: none"> 24 VDC+ Input/Output 0 V Input/Output FE 																			



**IP67-MT67MC-M8
Network Module**



Pin Definition (Data Port)			
M8 A-code Female	Connection Type	2 x M8 D-code; 4-pin Female	ETH0 , ETH1 1. TX+ 2. RX+ 3. TX- 4. RX-
	Physical layer	Ethernet	
	Transfer rate	10/100 Mbps, full duplex	
	Characteristic	Compliant with the protocol	
	Alarm function	Diagnostic&process alarms	
	Min. Cycle Time	250 μs	
	Port fixed torque	M8:0.5Nm	

Basic parameters	
Housing material	Aluminum alloy
Housing color	Anodized black
Protection level	IP67 , epoxy full potting
Dimensions (W x H x D)	155mm x 30mm x 31.9mm
Weight	208g
Operating temperature	-25°C...70°C
Storage temperature	-40°C...85°C
Operating humidity	5%...95%
Storage humidity	5%...95%
Operating Atmospheric pressure	80KPa...106KPa
Storage Atmospheric pressure	80KPa...106KPa
Tightening torque (IO)	M8:0.5Nm
Application Environment	According to EN-61131
Vibration Test	According to IEC60068-2
Impact Test	According to IEC60068-27
Free Drop Test	According to IEC60068-32
EMC	According to IEC61000-4-2;-3;-4
Certification	CE,RoHS
Mounting Hole size	Φ4.5mm x 2

Pin Definition (Power Port)			
Power Supply Port	Connection Type	M8, 4pol, A-code, Female&Male	PWR_IN PWR_OUT Male Female 1. +24V_Us 2. +24V_Ua 3. GND_Us 4. GND_Ua
	System voltage Us	18...30 VDC (type.24VDC)	
	Auxiliary voltage Ua	18...30 VDC (type.24VDC)	
	Current sum Is	4A	
	Current sum Ia	4A	
M8 A-code Female& Male	No-load current Ic	≤150mA	
	Reverse power protection	Yes	
	Tightening torque (Power)	M8:0.5Nm	



IP67-MT67MC-M8 Network Module

Order Information				
Interface	Model	Order No.	Description	I/O Connection Type
	MT67MC-EC-DI8P-M8	40000024	8 channel input, PNP IP67 Network Module	M8, 3pin Female, A-code
	MT67MC-PN-DI8P-M8	40000064		
	MT67MC-EI-DI8P-M8	40000160		

Digital Input	
Digital Inputs	Max. 8
Input Type	3-wire PNP sensor or 2-wire passive signal
Input Voltage	11...30 VDC
Diagnosis	Power supply short circuit diagnosis
Switch threshold	EN 61131-2 Type 1/3
Switch frequency	250 Hz
Input delay	20 µs
Max. input current	6 mA

Module LED					
EtherCat		ProfiNet		EtherNet/IP	
PWR	GN: module power normally				
	RD: module power reverse				
L/A0 L/A1	GN: channel signal normally				
	GN flash: extended communication normally				
I/O	GN: channel signal normally				
	RD: port power supply short circuit				
BUS	GN: OP status	BUS	Off: module work normally	BUS	GN: module work normally
	GN flash (slowly): SAFEOP status		RD: module work abnormally		GN flash: unconfigured / unlinked
	GN flash (quickly): Pre-OP status		RD flash: device Name / IP error		RD flash: device Name / IP error
	light off: Init status				
	RD&GN flash: communication error				

Pin Definition (I/O port)																				
	Pins	Address																		
I/O port	M8(X1~X8)	<table border="1"> <thead> <tr> <th>Byte</th> <th>0</th> </tr> </thead> <tbody> <tr> <td>Bit0</td> <td>X1P4</td> </tr> <tr> <td>Bit1</td> <td>X2P4</td> </tr> <tr> <td>Bit2</td> <td>X3P4</td> </tr> <tr> <td>Bit3</td> <td>X4P4</td> </tr> <tr> <td>Bit4</td> <td>X5P4</td> </tr> <tr> <td>Bit5</td> <td>X6P4</td> </tr> <tr> <td>Bit6</td> <td>X7P4</td> </tr> <tr> <td>Bit7</td> <td>X8P4</td> </tr> </tbody> </table>	Byte	0	Bit0	X1P4	Bit1	X2P4	Bit2	X3P4	Bit3	X4P4	Bit4	X5P4	Bit5	X6P4	Bit6	X7P4	Bit7	X8P4
	Byte		0																	
Bit0	X1P4																			
Bit1	X2P4																			
Bit2	X3P4																			
Bit3	X4P4																			
Bit4	X5P4																			
Bit5	X6P4																			
Bit6	X7P4																			
Bit7	X8P4																			
M8 A-code Female	<p>PNP</p> <p>Input</p> <p>1. 24 VDC+</p> <p>4. Input</p> <p>3. 0 V</p>																			



Order Information				
Interface	Model	Order No.	Description	I/O Connection Type
	MT67MC-EC-DI8N-M8	40000031	8 channel input, NPN IP67 Network Module	M8, 3pin Female, A-code
	MT67MC-PN-DI8N-M8	40000065		
	MT67MC-EI-DI8N-M8	40000248		

Digital Input	
Digital Inputs	Max. 8
Input Type	3-wire PNP sensor or 2-wire passive signal
Input Voltage	0...5 VDC
Diagnosis	Power supply short circuit diagnosis
Switch threshold	EN 61131-2 Type 1/3
Switch frequency	250 Hz
Input delay	20 µs
Max. input current	6 mA

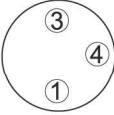
Module LED					
EtherCat		ProfiNet		EtherNet/IP	
PWR	GN: module power normally				
	RD: module power reverse				
L/A0 L/A1	GN: channel signal normally				
	GN flash: extended communication normally				
I/O	GN: channel signal normally				
	RD: port power supply short circuit				
BUS	GN: OP status	BUS	Off: module work normally	BUS	GN: module work normally
	GN flash (slowly): SAFEOP status		RD: module work abnormally		GN flash: unconfigured / unlinked
	GN flash (quickly): Pre-OP status		RD flash: device Name / IP error		RD flash: device Name / IP error
	light off: Init status				
	RD&GN flash: communication error				

Pin Definition (I/O port)																				
	Pins	Address																		
I/O port	M8(X1~X8)	<table border="1"> <thead> <tr> <th>Byte</th> <th>0</th> </tr> </thead> <tbody> <tr> <td>Bit0</td> <td>X1P4</td> </tr> <tr> <td>Bit1</td> <td>X2P4</td> </tr> <tr> <td>Bit2</td> <td>X3P4</td> </tr> <tr> <td>Bit3</td> <td>X4P4</td> </tr> <tr> <td>Bit4</td> <td>X5P4</td> </tr> <tr> <td>Bit5</td> <td>X6P4</td> </tr> <tr> <td>Bit6</td> <td>X7P4</td> </tr> <tr> <td>Bit7</td> <td>X8P4</td> </tr> </tbody> </table>	Byte	0	Bit0	X1P4	Bit1	X2P4	Bit2	X3P4	Bit3	X4P4	Bit4	X5P4	Bit5	X6P4	Bit6	X7P4	Bit7	X8P4
	Byte		0																	
Bit0	X1P4																			
Bit1	X2P4																			
Bit2	X3P4																			
Bit3	X4P4																			
Bit4	X5P4																			
Bit5	X6P4																			
Bit6	X7P4																			
Bit7	X8P4																			
M8 A-code Female	 <p>NPN</p> <p>Input</p> <p>1. 24 VDC+</p> <p>4. Input</p> <p>3. 0 V</p>																			



IP67-MT67MC-M8 Network Module

Order Information				
Interface	Model	Order No.	Description	I/O Connection Type
	MT67MC-EC-DO8P-M8-0.5A	40000025	8 channel output, PNP IP67 Network Module	M8, 3pin Female, A-code
	MT67MC-PN-DO8P-M8-0.5A	40000068		
	MT67MC-EI-DO8P-M8-0.5A	40000164		

Digital Output	
Digital Outputs	Max. 8
Output Voltage	18...30 VDC
Output Current	0.5A/ch
Diagnosis	point diagnosis
Sync. Factor	1
Switch frequency	250 Hz
Load Type	Resistive, Inductive, Lamp

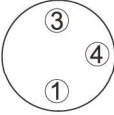
Module LED					
EtherCat		ProfiNet		EtherNet/IP	
PWR	GN: module power normally				
	RD: module power reverse				
L/A0 L/A1	GN: channel signal normally				
	GN flash: extended communication normally				
I/O	GN: channel signal normally				
	RD: port power supply short circuit				
BUS	GN: OP status	BUS	Off: module work normally	BUS	GN: module work normally
	GN flash (slowly): SAFEOP status		RD: module work abnormally		GN flash: unconfigured / unlinked
	GN flash (quickly): Pre-OP status		RD flash: device Name / IP error		RD flash: device Name / IP error
	light off: Init status				
	RD&GN flash: communication error				

Pin Definition (I/O port)																			
	Pins	Address																	
I/O port	M8(X1~X8)																		
	 <p>PNP</p> <p>Output</p> <p>1. N/C 4. Output 3. 0 V</p>	<table border="1"> <thead> <tr> <th>Byte</th> <th>0</th> </tr> </thead> <tbody> <tr> <td>Bit0</td> <td>X1P4</td> </tr> <tr> <td>Bit1</td> <td>X2P4</td> </tr> <tr> <td>Bit2</td> <td>X3P4</td> </tr> <tr> <td>Bit3</td> <td>X4P4</td> </tr> <tr> <td>Bit4</td> <td>X5P4</td> </tr> <tr> <td>Bit5</td> <td>X6P4</td> </tr> <tr> <td>Bit6</td> <td>X7P4</td> </tr> <tr> <td>Bit7</td> <td>X8P4</td> </tr> </tbody> </table>	Byte	0	Bit0	X1P4	Bit1	X2P4	Bit2	X3P4	Bit3	X4P4	Bit4	X5P4	Bit5	X6P4	Bit6	X7P4	Bit7
Byte	0																		
Bit0	X1P4																		
Bit1	X2P4																		
Bit2	X3P4																		
Bit3	X4P4																		
Bit4	X5P4																		
Bit5	X6P4																		
Bit6	X7P4																		
Bit7	X8P4																		
M8 A-code Female																			



Order Information				
Interface	Model	Order No.	Description	I/O Connection Type
	MT67MC-EC-DO8N-M8-0.5A	40000042	8 channel output, NPN IP67 Network Module	M8, 3pin Female, A-code
	MT67MC-PN-DO8N-M8-0.5A	40000071		
	MT67MC-EI-DO8N-M8-0.5A	40000157		

Digital Output	
Digital Outputs	Max. 8
Output Voltage	0 VDC
Output Current	0.5A/ch
Diagnosis	point diagnosis
Sync. Factor	1
Switch frequency	250 Hz
Load Type	Resistive, Inductive, Lamp

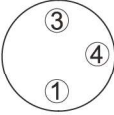
Module LED					
EtherCat		ProfiNet		EtherNet/IP	
PWR	GN: module power normally				
	RD: module power reverse				
L/A0 L/A1	GN: channel signal normally				
	GN flash: extended communication normally				
I/O	GN: channel signal normally				
	RD: port power supply short circuit				
BUS	GN: OP status	BUS	Off: module work normally	BUS	GN: module work normally
	GN flash (slowly): SAFEOP status		RD: module work abnormally		GN flash: unconfigured / unlinked
	GN flash (quickly): Pre-OP status		RD flash: device Name / IP error		RD flash: device Name / IP error
	light off: Init status				
	RD&GN flash: communication error				

Pin Definition (I/O port)																				
	Pins	Address																		
I/O port	M8(X1~X8)	<table border="1"> <thead> <tr> <th>Byte</th> <th>0</th> </tr> </thead> <tbody> <tr> <td>Bit0</td> <td>X1P4</td> </tr> <tr> <td>Bit1</td> <td>X2P4</td> </tr> <tr> <td>Bit2</td> <td>X3P4</td> </tr> <tr> <td>Bit3</td> <td>X4P4</td> </tr> <tr> <td>Bit4</td> <td>X5P4</td> </tr> <tr> <td>Bit5</td> <td>X6P4</td> </tr> <tr> <td>Bit6</td> <td>X7P4</td> </tr> <tr> <td>Bit7</td> <td>X8P4</td> </tr> </tbody> </table>	Byte	0	Bit0	X1P4	Bit1	X2P4	Bit2	X3P4	Bit3	X4P4	Bit4	X5P4	Bit5	X6P4	Bit6	X7P4	Bit7	X8P4
	Byte		0																	
Bit0	X1P4																			
Bit1	X2P4																			
Bit2	X3P4																			
Bit3	X4P4																			
Bit4	X5P4																			
Bit5	X6P4																			
Bit6	X7P4																			
Bit7	X8P4																			
M8 A-code Female	 <p>NPN</p> <p>Output</p> <p>1. 24VDC+</p> <p>4. Output</p> <p>3. N/C</p>																			

IP67-MT67MC-M8 Network Module



Order Information				
Interface	Model	Order No.	Description	I/O Connection Type
	MT67MC-EC-DIO8P-M8-0.5A	40000135	16 channel, PNP adaptive input/output IP67 Network Module	M8, 3pin Female, A-code
	MT67MC-PN-DIO8P-M8-0.5A	40000106		
	MT67MC-EI-DIO8P-M8-0.5A	40000251		

Digital Input	
Digital Inputs	Max. 8
Input Type	3-wire PNP sensor or 2-wire passive signal
Input Voltage	11...30 VDC
Diagnosis	Power supply short circuit diagnosis
Switch threshold	EN 61131-2 Type 1/3
Switch frequency	250 Hz
Input delay	20 µs
Max. input current	6 mA

Digital Output	
Digital Outputs	Max. 8
Output Voltage	18...30 VDC
Output Current	0.5A/ch
Diagnosis	point diagnosis
Sync. Factor	1
Switch frequency	250 Hz
Load Type	Resistive, Inductive, Lamp

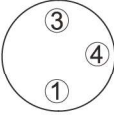
Module LED				
EtherCat		ProfiNet		EtherNet/IP
PWR	GN: module power normally			
	RD: module power reverse			
L/A0 L/A1	GN: channel signal normally			
	GN flash: extended communication normally			
I/O	GN: channel signal normally			
	RD: port power supply short circuit			
BUS	GN: OP status	BUS	Off: module work normally	BUS
	GN flash (slowly): SAFEOP status		RD: module work abnormally	
	GN flash (quickly): Pre-OP status		RD flash: device Name / IP error	
	light off: Init status			
	RD&GN flash: communication error			
			GN: module work normally	
			GN flash: unconfigured / unlinked	
			RD flash: device Name / IP error	

Pin Definition (I/O port)																			
	Pins	Address																	
I/O port	M8(X1~X8)																		
	 <p>PNP Input/Output 1. 24 VDC+ 4. Input/Output 3. 0 V</p>	<table border="1"> <thead> <tr> <th>Byte</th> <th>0</th> </tr> </thead> <tbody> <tr> <td>Bit0</td> <td>X1P4</td> </tr> <tr> <td>Bit1</td> <td>X2P4</td> </tr> <tr> <td>Bit2</td> <td>X3P4</td> </tr> <tr> <td>Bit3</td> <td>X4P4</td> </tr> <tr> <td>Bit4</td> <td>X5P4</td> </tr> <tr> <td>Bit5</td> <td>X6P4</td> </tr> <tr> <td>Bit6</td> <td>X7P4</td> </tr> <tr> <td>Bit7</td> <td>X8P4</td> </tr> </tbody> </table>	Byte	0	Bit0	X1P4	Bit1	X2P4	Bit2	X3P4	Bit3	X4P4	Bit4	X5P4	Bit5	X6P4	Bit6	X7P4	Bit7
Byte	0																		
Bit0	X1P4																		
Bit1	X2P4																		
Bit2	X3P4																		
Bit3	X4P4																		
Bit4	X5P4																		
Bit5	X6P4																		
Bit6	X7P4																		
Bit7	X8P4																		
M8 A-code Female																			

Order Information				
Interface	Model	Order No.	Description	I/O Connection Type
	MT67MC-EC-DIO8N-M8-0.5A	40000243	16 channel,NPN adaptive input/output IP67 Network Module	M8, 3pin Female, A-code
	MT67MC-PN-DIO8N-M8-0.5A	40000107		
	MT67MC-EI-DIO8N-M8-0.5A	40000252		

Digital Input	
Digital Inputs	Max. 8
Input Type	3-wire PNP sensor or 2-wire passive signal
Input Voltage	0...5 VDC
Diagnosis	Power supply short circuit diagnosis
Switch threshold	EN 61131-2 Type 1/3
Switch frequency	250 Hz
Input delay	20 µs
Max. input current	6 mA

Digital Output	
Digital Outputs	Max. 8
Output Voltage	0 VDC
Output Current	0.5A/ch
Diagnosis	point diagnosis
Sync. Factor	1
Switch frequency	250 Hz
Load Type	Resistive, Inductive, Lamp

Module LED					
EtherCat		ProfiNet		EtherNet/IP	
PWR			GN: module power normally		
			RD: module power reverse		
L/A0 L/A1			GN: channel signal normally		
			GN flash: extended communication normally		
I/O			GN: channel signal normally		
			RD: port power supply short circuit		
BUS	GN: OP status	BUS	Off: module work normally	BUS	GN: module work normally
	GN flash (slowly): SAFEOP status		RD: module work abnormally		GN flash: unconfigured / unlinked
	GN flash (quickly): Pre-OP status		RD flash: device Name / IP error		RD flash: device Name / IP error
	light off: Init status				
	RD&GN flash: communication error				

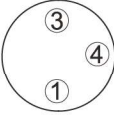
Pin Definition (I/O port)																			
	Pins	Address																	
I/O port	M8(X1~X8)																		
	 <p>NPN Input/Output 1. 24 VDC+ 4. Input/Output 3. 0 V</p>	<table border="1"> <thead> <tr> <th>Byte</th> <th>0</th> </tr> </thead> <tbody> <tr> <td>Bit0</td> <td>X1P4</td> </tr> <tr> <td>Bit1</td> <td>X2P4</td> </tr> <tr> <td>Bit2</td> <td>X3P4</td> </tr> <tr> <td>Bit3</td> <td>X4P4</td> </tr> <tr> <td>Bit4</td> <td>X5P4</td> </tr> <tr> <td>Bit5</td> <td>X6P4</td> </tr> <tr> <td>Bit6</td> <td>X7P4</td> </tr> <tr> <td>Bit7</td> <td>X8P4</td> </tr> </tbody> </table>	Byte	0	Bit0	X1P4	Bit1	X2P4	Bit2	X3P4	Bit3	X4P4	Bit4	X5P4	Bit5	X6P4	Bit6	X7P4	Bit7
Byte	0																		
Bit0	X1P4																		
Bit1	X2P4																		
Bit2	X3P4																		
Bit3	X4P4																		
Bit4	X5P4																		
Bit5	X6P4																		
Bit6	X7P4																		
Bit7	X8P4																		
M8 A-code Female																			



**IP67-MT67MC-M8
Network Module**

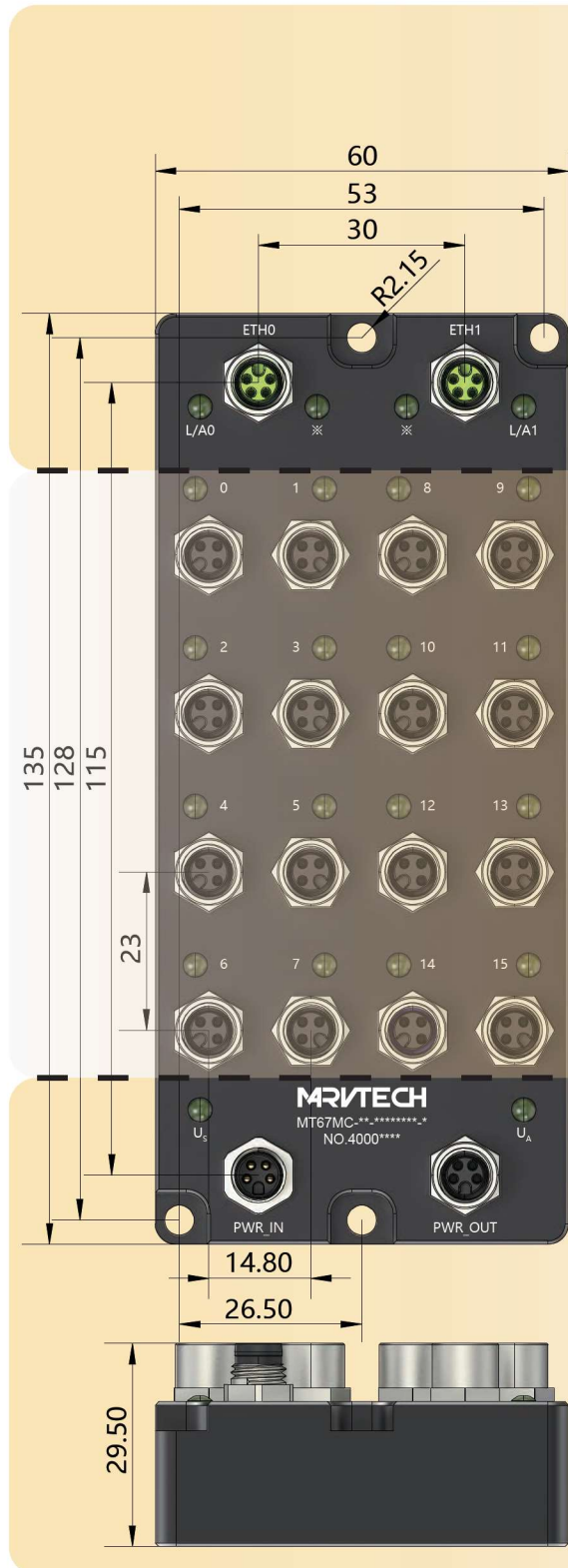



Pin Definition (Data Port)			
M8 A-code Female	Connection Type	2 × M8 A-code; 4-pol,Female;	ETH0 , ETH1 1. TX+ 2. RX+ 4. TX- 3. RX-
	Physical layer	Ethernet	
	Transfer rate	10/100 Mbps, Full Duplex	
	Min. Cycle Time	1 ms	
	Tightening torque (Data)	M8 : 0.5Nm	

Basic parameters	
Housing material	Aluminum alloy
Housing color	Metallic Silver
Protection level	IP67
Dimensions (W x H x D)	135mm × 60mm × 29.5mm
Weight	410g
Operating temperature	-25°C...70°C
Storage temperature	-40°C...85°C
Operating humidity	5%...95%
Storage humidity	5%...95%
Operating Atmospheric pressure	80KPa...106KPa
Storage Atmospheric pressure	80KPa...106KPa
Tightening torque(I/O)	M8:0.5Nm
Application Environment	According EN-61131
Vibration Test	According IEC60068-2
Impact Test	According IEC60068-27
Free Drop Test	According IEC60068-32
EMC	According IEC61000-4-2,-3,-4
Certification	CE,RoHS
Mounting Hole size	Φ4.5mm × 2

Pin Definition (Power Port)			
Power Supply Port	Connection (Power port)	M8, 4pol, A-code, Female&Male	PWR_IN PWR_OUT Male Female 1. +24V_Us 2. +24V_Ua 3. GND_Us 4. GND_Ua
	System voltage Us	18...30 VDC (type.24VDC)	
	Auxiliary voltage Ua	18...30 VDC (type.24VDC)	
	Current sum Is	4A	
	Current sum Ia	4A	
M8 A-code Female&M ale	No-load current Ic	≤150mA	
	Reverse power protection	Yes	
	Tightening torque (Power)	M8:0.5Nm	



IP67-MT67MC-M8 Network Module

Order Information				
Interface	Model	Order No.	Description	Connection (I/O)
	MT67MC-EC-DI16P-M8	40000268	16 channel , PNP, Digital Input, IP67 Network Module	M8, 3pin Female, A-code
	MT67MC-PN-DI16P-M8	40000274		
	MT67MC-EI-DI16P-M8	40000280		

Digital Input	
Digital Inputs	Max. 16
Input Type	3-wire PNP sensor or 2-wire passive signal
Input Voltage	11...30 VDC
Diagnosis	Power supply short circuit diagnosis
Switch threshold	EN 61131-2 Type 1/3
Switch frequency	250 Hz
Input delay	20 µs
Max. input current	6 mA

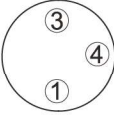
Module LED					
EtherCat		ProfiNet		EtherNet/IP	
PWR			GN: module power normally		
			RD: module power reverse		
L/A0 L/A1			GN: channel signal normally		
			GN flash: extended communication normally		
I/O			GN: channel signal normally		
			RD: port power supply short circuit		
BUS	GN: OP status	BUS	Off: module work normally	BUS	GN: module work normally
	GN flash (slowly): SAFEOP status		RD: module work abnormally		GN flash: unconfigured / unlinked
	GN flash (quickly): Pre-OP status		RD flash: device Name / IP error		RD flash: device Name / IP error
	light off: Init status				
	RD&GN flash: communication error				

Pin Definition (I/O port)																																					
	Pins	Address																																			
I/O port	M8(X1~X8)																																				
	 <p style="text-align: center;">PNP</p> <p style="text-align: center;">Input</p> <p>1. 24 VDC+</p> <p>4. Input</p> <p>3. 0 V</p>	<table border="1"> <thead> <tr> <th>Byte</th> <th>0</th> <th>Byte</th> <th>1</th> </tr> </thead> <tbody> <tr> <td>Bit0</td> <td>X1P4</td> <td>Bit0</td> <td>X9P4</td> </tr> <tr> <td>Bit1</td> <td>X2P4</td> <td>Bit1</td> <td>X10P4</td> </tr> <tr> <td>Bit2</td> <td>X3P4</td> <td>Bit2</td> <td>X11P4</td> </tr> <tr> <td>Bit3</td> <td>X4P4</td> <td>Bit3</td> <td>X12P4</td> </tr> <tr> <td>Bit4</td> <td>X5P4</td> <td>Bit4</td> <td>X13P4</td> </tr> <tr> <td>Bit5</td> <td>X6P4</td> <td>Bit5</td> <td>X14P4</td> </tr> <tr> <td>Bit6</td> <td>X7P4</td> <td>Bit6</td> <td>X15P4</td> </tr> <tr> <td>Bit7</td> <td>X8P4</td> <td>Bit7</td> <td>X16P4</td> </tr> </tbody> </table>	Byte	0	Byte	1	Bit0	X1P4	Bit0	X9P4	Bit1	X2P4	Bit1	X10P4	Bit2	X3P4	Bit2	X11P4	Bit3	X4P4	Bit3	X12P4	Bit4	X5P4	Bit4	X13P4	Bit5	X6P4	Bit5	X14P4	Bit6	X7P4	Bit6	X15P4	Bit7	X8P4	Bit7
Byte	0	Byte	1																																		
Bit0	X1P4	Bit0	X9P4																																		
Bit1	X2P4	Bit1	X10P4																																		
Bit2	X3P4	Bit2	X11P4																																		
Bit3	X4P4	Bit3	X12P4																																		
Bit4	X5P4	Bit4	X13P4																																		
Bit5	X6P4	Bit5	X14P4																																		
Bit6	X7P4	Bit6	X15P4																																		
Bit7	X8P4	Bit7	X16P4																																		
M12 A-code female																																					



Order Information				
Interface	Model	Order No.	Description	Connection (I/O)
	MT67MC-EC-DI16N-M8	40000269	16 channel , NPN, Digital Input, IP67 Network Module	M8, 3pin Female, A-code
	MT67MC-PN-DI16N-M8	40000275		
	MT67MC-EI-DI16N-M8	40000281		

Digital Input	
Digital Inputs	Max. 16
Input Type	3-wire PNP sensor or 2-wire passive signal
Input Voltage	0...5 VDC
Diagnosis	Power supply short circuit diagnosis
Switch threshold	EN 61131-2 Type 1/3
Switch frequency	250 Hz
Input delay	20 µs
Max. input current	6 mA

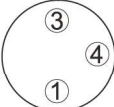
Module LED					
EtherCat		ProfiNet		EtherNet/IP	
PWR			GN: module power normally		
			RD: module power reverse		
L/A0 L/A1			GN: channel signal normally		
			GN flash: extended communication normally		
I/O			GN: channel signal normally		
			RD: port power supply short circuit		
BUS	GN: OP status	BUS	Off: module work normally	BUS	GN: module work normally
	GN flash (slowly): SAFEOP status		RD: module work abnormally		GN flash: unconfigured / unlinked
	GN flash (quickly): Pre-OP status		RD flash: device Name / IP error		RD flash: device Name / IP error
	light off: Init status				
	RD&GN flash: communication error				

Pin Definition (I/O port)																																						
I/O port	Pins	Address																																				
	M12 A-code female	<p>M8(X1~X8)</p>  <p>NPN</p> <p>Input</p> <p>1. 24 VDC+ 4. Input 3. 0 V</p>	<table border="1"> <thead> <tr> <th>Byte</th> <th>0</th> <th>Byte</th> <th>1</th> </tr> </thead> <tbody> <tr> <td>Bit0</td> <td>X1P4</td> <td>Bit0</td> <td>X9P4</td> </tr> <tr> <td>Bit1</td> <td>X2P4</td> <td>Bit1</td> <td>X10P4</td> </tr> <tr> <td>Bit2</td> <td>X3P4</td> <td>Bit2</td> <td>X11P4</td> </tr> <tr> <td>Bit3</td> <td>X4P4</td> <td>Bit3</td> <td>X12P4</td> </tr> <tr> <td>Bit4</td> <td>X5P4</td> <td>Bit4</td> <td>X13P4</td> </tr> <tr> <td>Bit5</td> <td>X6P4</td> <td>Bit5</td> <td>X14P4</td> </tr> <tr> <td>Bit6</td> <td>X7P4</td> <td>Bit6</td> <td>X15P4</td> </tr> <tr> <td>Bit7</td> <td>X8P4</td> <td>Bit7</td> <td>X16P4</td> </tr> </tbody> </table>	Byte	0	Byte	1	Bit0	X1P4	Bit0	X9P4	Bit1	X2P4	Bit1	X10P4	Bit2	X3P4	Bit2	X11P4	Bit3	X4P4	Bit3	X12P4	Bit4	X5P4	Bit4	X13P4	Bit5	X6P4	Bit5	X14P4	Bit6	X7P4	Bit6	X15P4	Bit7	X8P4	Bit7
Byte	0	Byte	1																																			
Bit0	X1P4	Bit0	X9P4																																			
Bit1	X2P4	Bit1	X10P4																																			
Bit2	X3P4	Bit2	X11P4																																			
Bit3	X4P4	Bit3	X12P4																																			
Bit4	X5P4	Bit4	X13P4																																			
Bit5	X6P4	Bit5	X14P4																																			
Bit6	X7P4	Bit6	X15P4																																			
Bit7	X8P4	Bit7	X16P4																																			



IP67-MT67MC-M8 Network Module

Order Information				
Interface	Model	Order No.	Description	Connection (I/O)
	MT67MC-EC-DO16P-M8-0.5A	40000270	16 channel , PNP, Digital Output, IP67 Network Module	M8, 3pin Female, A-code
	MT67MC-PN-DO16P-M8-0.5A	40000276		
	MT67MC-EI-DO16P-M8-0.5A	40000282		

Digital Output	
Digital Outputs	Max. 16
Output Voltage	18...30 VDC
Output Current	0.5A/ch
Diagnosis	point diagnosis
Sync. Factor	1
Switch frequency	250 Hz
Load Type	Resistive, Inductive, Lamp

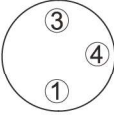
Module LED					
EtherCat		ProfiNet		EtherNet/IP	
PWR	GN: module power normally				
	RD: module power reverse				
L/A0 L/A1	GN: channel signal normally				
	GN flash: extended communication normally				
I/O	GN: channel signal normally				
	RD: port power supply short circuit				
BUS	GN: OP status	BUS	Off: module work normally	BUS	GN: module work normally
	GN flash (slowly): SAFEOP status		RD: module work abnormally		GN flash: unconfigured / unlinked
	GN flash (quickly): Pre-OP status		RD flash: device Name / IP error		RD flash: device Name / IP error
	light off: Init status				
	RD&GN flash: communication error				

Pin Definition (I/O port)																																						
I/O port	Pins	Address																																				
	M12 A-code female	<p>M8(X1~X8)</p>  <p>PNP</p> <p>Output</p> <p>1. N/C 4. Output 3. 0 V</p>	<table border="1"> <thead> <tr> <th>Byte</th> <th>0</th> <th>Byte</th> <th>1</th> </tr> </thead> <tbody> <tr> <td>Bit0</td> <td>X1P4</td> <td>Bit0</td> <td>X9P4</td> </tr> <tr> <td>Bit1</td> <td>X2P4</td> <td>Bit1</td> <td>X10P4</td> </tr> <tr> <td>Bit2</td> <td>X3P4</td> <td>Bit2</td> <td>X11P4</td> </tr> <tr> <td>Bit3</td> <td>X4P4</td> <td>Bit3</td> <td>X12P4</td> </tr> <tr> <td>Bit4</td> <td>X5P4</td> <td>Bit4</td> <td>X13P4</td> </tr> <tr> <td>Bit5</td> <td>X6P4</td> <td>Bit5</td> <td>X14P4</td> </tr> <tr> <td>Bit6</td> <td>X7P4</td> <td>Bit6</td> <td>X15P4</td> </tr> <tr> <td>Bit7</td> <td>X8P4</td> <td>Bit7</td> <td>X16P4</td> </tr> </tbody> </table>	Byte	0	Byte	1	Bit0	X1P4	Bit0	X9P4	Bit1	X2P4	Bit1	X10P4	Bit2	X3P4	Bit2	X11P4	Bit3	X4P4	Bit3	X12P4	Bit4	X5P4	Bit4	X13P4	Bit5	X6P4	Bit5	X14P4	Bit6	X7P4	Bit6	X15P4	Bit7	X8P4	Bit7
Byte	0	Byte	1																																			
Bit0	X1P4	Bit0	X9P4																																			
Bit1	X2P4	Bit1	X10P4																																			
Bit2	X3P4	Bit2	X11P4																																			
Bit3	X4P4	Bit3	X12P4																																			
Bit4	X5P4	Bit4	X13P4																																			
Bit5	X6P4	Bit5	X14P4																																			
Bit6	X7P4	Bit6	X15P4																																			
Bit7	X8P4	Bit7	X16P4																																			



Order Information				
Interface	Model	Order No.	Description	Connection (I/O)
	MT67MC-EC-DO16N-M8-0.5A	40000271	16 channel , NPN, Digital Output, IP67 Network Module	M8, 3pin Female, A-code
	MT67MC-PN-DO16N-M8-0.5A	40000277		
	MT67MC-EI-DO16N-M8-0.5A	40000283		

Digital Output	
Digital Outputs	Max. 16
Output Voltage	0 VDC
Output Current	0.5A/ch
Diagnosis	point diagnosis
Sync. Factor	1
Switch frequency	250 Hz
Load Type	Resistive, Inductive, Lamp

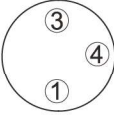
Module LED					
EtherCat		ProfiNet		EtherNet/IP	
PWR			GN: module power normally		
			RD: module power reverse		
L/A0 L/A1			GN: channel signal normally		
			GN flash: extended communication normally		
I/O			GN: channel signal normally		
			RD: port power supply short circuit		
BUS	GN: OP status	BUS	Off: module work normally	BUS	GN: module work normally
	GN flash (slowly): SAFEOP status		RD: module work abnormally		GN flash: unconfigured / unlinked
	GN flash (quickly): Pre-OP status		RD flash: device Name / IP error		RD flash: device Name / IP error
	light off: Init status				
	RD&GN flash: communication error				

Pin Definition (I/O port)																																						
I/O port	Pins	Address																																				
	M12 A-code female	<p>M8(X1~X8)</p>  <p>NPN</p> <p>Output</p> <p>1. 24VDC+ 4. Output 3. N/C</p>	<table border="1"> <thead> <tr> <th>Byte</th> <th>0</th> <th>Byte</th> <th>1</th> </tr> </thead> <tbody> <tr> <td>Bit0</td> <td>X1P4</td> <td>Bit0</td> <td>X9P4</td> </tr> <tr> <td>Bit1</td> <td>X2P4</td> <td>Bit1</td> <td>X10P4</td> </tr> <tr> <td>Bit2</td> <td>X3P4</td> <td>Bit2</td> <td>X11P4</td> </tr> <tr> <td>Bit3</td> <td>X4P4</td> <td>Bit3</td> <td>X12P4</td> </tr> <tr> <td>Bit4</td> <td>X5P4</td> <td>Bit4</td> <td>X13P4</td> </tr> <tr> <td>Bit5</td> <td>X6P4</td> <td>Bit5</td> <td>X14P4</td> </tr> <tr> <td>Bit6</td> <td>X7P4</td> <td>Bit6</td> <td>X15P4</td> </tr> <tr> <td>Bit7</td> <td>X8P4</td> <td>Bit7</td> <td>X16P4</td> </tr> </tbody> </table>	Byte	0	Byte	1	Bit0	X1P4	Bit0	X9P4	Bit1	X2P4	Bit1	X10P4	Bit2	X3P4	Bit2	X11P4	Bit3	X4P4	Bit3	X12P4	Bit4	X5P4	Bit4	X13P4	Bit5	X6P4	Bit5	X14P4	Bit6	X7P4	Bit6	X15P4	Bit7	X8P4	Bit7
Byte	0	Byte	1																																			
Bit0	X1P4	Bit0	X9P4																																			
Bit1	X2P4	Bit1	X10P4																																			
Bit2	X3P4	Bit2	X11P4																																			
Bit3	X4P4	Bit3	X12P4																																			
Bit4	X5P4	Bit4	X13P4																																			
Bit5	X6P4	Bit5	X14P4																																			
Bit6	X7P4	Bit6	X15P4																																			
Bit7	X8P4	Bit7	X16P4																																			

IP67-MT67MC-M8 Network Module



Order Information				
Interface	Model	Order No.	Description	Connection (I/O)
	MT67MC-EC-DI8PDO8P-M8-0.5A	40000272	8 channel Digital Input, PNP 8 channel Digital Output, PNP IP67 Network Module	M8, 3pin Female, A-code
	MT67MC-PN-DI8PDO8P-M8-0.5A	40000278		
	MT67MC-EI-DI8PDO8P-M8-0.5A	40000284		

Digital Input	
Digital Inputs	Max. 8
Input Type	3-wire PNP sensor or 2-wire passive signal
Input Voltage	11...30 VDC
Diagnosis	Power supply short circuit diagnosis
Switch threshold	EN 61131-2 Type 1/3
Switch frequency	250 Hz
Input delay	20 µs
Max. input current	6 mA

Digital Output	
Digital Outputs	Max. 8
Output Voltage	18...30 VDC
Output Current	0.5A/ch
Diagnosis	point diagnosis
Sync. Factor	1
Switch frequency	250 Hz
Load Type	Resistive, Inductive, Lamp

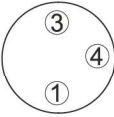
Module LED					
EtherCat		ProfiNet		EtherNet/IP	
PWR	GN: module power normally				
	RD: module power reverse				
L/A0 L/A1	GN: channel signal normally				
	GN flash: extended communication normally				
I/O	GN: channel signal normally				
	RD: port power supply short circuit				
BUS	GN: OP status	BUS	Off: module work normally	BUS	GN: module work normally
	GN flash (slowly): SAFEOP status		RD: module work abnormally		GN flash: unconfigured / unlinked
	GN flash (quickly): Pre-OP status		RD flash: device Name / IP error		RD flash: device Name / IP error
	light off: Init status				
	RD&GN flash: communication error				

Pin Definition (I/O port)																																						
I/O port	Pins	Address																																				
	M12 A-code female	<p>M8(X1~X8)</p>  <p>PNP Input</p> <p>1. 24 VDC+ 4. Input 3. 0 V</p> <p>PNP Output</p> <p>1. N/C 4. Output 3. 0 V</p>	<table border="1"> <thead> <tr> <th>Byte</th> <th>0</th> <th>Byte</th> <th>1</th> </tr> </thead> <tbody> <tr> <td>Bit0</td> <td>X1P4</td> <td>Bit0</td> <td>X9P4</td> </tr> <tr> <td>Bit1</td> <td>X2P4</td> <td>Bit1</td> <td>X10P4</td> </tr> <tr> <td>Bit2</td> <td>X3P4</td> <td>Bit2</td> <td>X11P4</td> </tr> <tr> <td>Bit3</td> <td>X4P4</td> <td>Bit3</td> <td>X12P4</td> </tr> <tr> <td>Bit4</td> <td>X5P4</td> <td>Bit4</td> <td>X13P4</td> </tr> <tr> <td>Bit5</td> <td>X6P4</td> <td>Bit5</td> <td>X14P4</td> </tr> <tr> <td>Bit6</td> <td>X7P4</td> <td>Bit6</td> <td>X15P4</td> </tr> <tr> <td>Bit7</td> <td>X8P4</td> <td>Bit7</td> <td>X16P4</td> </tr> </tbody> </table>	Byte	0	Byte	1	Bit0	X1P4	Bit0	X9P4	Bit1	X2P4	Bit1	X10P4	Bit2	X3P4	Bit2	X11P4	Bit3	X4P4	Bit3	X12P4	Bit4	X5P4	Bit4	X13P4	Bit5	X6P4	Bit5	X14P4	Bit6	X7P4	Bit6	X15P4	Bit7	X8P4	Bit7
Byte	0	Byte	1																																			
Bit0	X1P4	Bit0	X9P4																																			
Bit1	X2P4	Bit1	X10P4																																			
Bit2	X3P4	Bit2	X11P4																																			
Bit3	X4P4	Bit3	X12P4																																			
Bit4	X5P4	Bit4	X13P4																																			
Bit5	X6P4	Bit5	X14P4																																			
Bit6	X7P4	Bit6	X15P4																																			
Bit7	X8P4	Bit7	X16P4																																			

Order Information				
Interface	Model	Order No.	Description	Connection (I/O)
	MT67MC-EC-DI8NDO8N-M8-0.5A	40000273	8 channel Digital Input, NPN 8 channel Digital Output, NPN IP67 Network Module	M8, 3pin Female, A-code
	MT67MC-PN-DI8NDO8N-M8-0.5A	40000279		
	MT67MC-EI-DI8NDO8N-M8-0.5A	40000285		

Digital Input	
Digital Inputs	Max. 8
Input Type	3-wire PNP sensor or 2-wire passive signal
Input Voltage	0...5 VDC
Diagnosis	Power supply short circuit diagnosis
Switch threshold	EN 61131-2 Type 1/3
Switch frequency	250 Hz
Input delay	20 µs
Max. input current	6 mA

Digital Output	
Digital Outputs	Max. 8
Output Voltage	0 VDC
Output Current	0.5A/ch
Diagnosis	point diagnosis
Sync. Factor	1
Switch frequency	250 Hz
Load Type	Resistive, Inductive, Lamp

Module LED				
EtherCat		ProfiNet		EtherNet/IP
PWR	GN: module power normally			
	RD: module power reverse			
L/A0 L/A1	GN: channel signal normally			
	GN flash: extended communication normally			
I/O	GN: channel signal normally			
	RD: port power supply short circuit			
BUS	GN: OP status	BUS	Off: module work normally	BUS
	GN flash (slowly): SAFEOP status		RD: module work abnormally	
	GN flash (quickly): Pre-OP status		RD flash: device Name / IP error	
	light off: Init status			
	RD&GN flash: communication error			
				GN: module work normally
				GN flash: unconfigured / unlinked
				RD flash: device Name / IP error

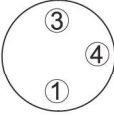
Pin Definition (I/O port)																																						
I/O port	Pins	Address																																				
	M12 A-code female	<p>M8(X1~X8)</p>  <p>NPN Input</p> <p>1. 24 VDC+ 4. Input 3. 0 V</p> <p>NPN Output</p> <p>1. 24VDC+ 4. Output 3. N/C</p>	<table border="1"> <thead> <tr> <th>Byte</th> <th>0</th> <th>Byte</th> <th>1</th> </tr> </thead> <tbody> <tr> <td>Bit0</td> <td>X1P4</td> <td>Bit0</td> <td>X9P4</td> </tr> <tr> <td>Bit1</td> <td>X2P4</td> <td>Bit1</td> <td>X10P4</td> </tr> <tr> <td>Bit2</td> <td>X3P4</td> <td>Bit2</td> <td>X11P4</td> </tr> <tr> <td>Bit3</td> <td>X4P4</td> <td>Bit3</td> <td>X12P4</td> </tr> <tr> <td>Bit4</td> <td>X5P4</td> <td>Bit4</td> <td>X13P4</td> </tr> <tr> <td>Bit5</td> <td>X6P4</td> <td>Bit5</td> <td>X14P4</td> </tr> <tr> <td>Bit6</td> <td>X7P4</td> <td>Bit6</td> <td>X15P4</td> </tr> <tr> <td>Bit7</td> <td>X8P4</td> <td>Bit7</td> <td>X16P4</td> </tr> </tbody> </table>	Byte	0	Byte	1	Bit0	X1P4	Bit0	X9P4	Bit1	X2P4	Bit1	X10P4	Bit2	X3P4	Bit2	X11P4	Bit3	X4P4	Bit3	X12P4	Bit4	X5P4	Bit4	X13P4	Bit5	X6P4	Bit5	X14P4	Bit6	X7P4	Bit6	X15P4	Bit7	X8P4	Bit7
Byte	0	Byte	1																																			
Bit0	X1P4	Bit0	X9P4																																			
Bit1	X2P4	Bit1	X10P4																																			
Bit2	X3P4	Bit2	X11P4																																			
Bit3	X4P4	Bit3	X12P4																																			
Bit4	X5P4	Bit4	X13P4																																			
Bit5	X6P4	Bit5	X14P4																																			
Bit6	X7P4	Bit6	X15P4																																			
Bit7	X8P4	Bit7	X16P4																																			



**IP20 MT20-16
Network Module**

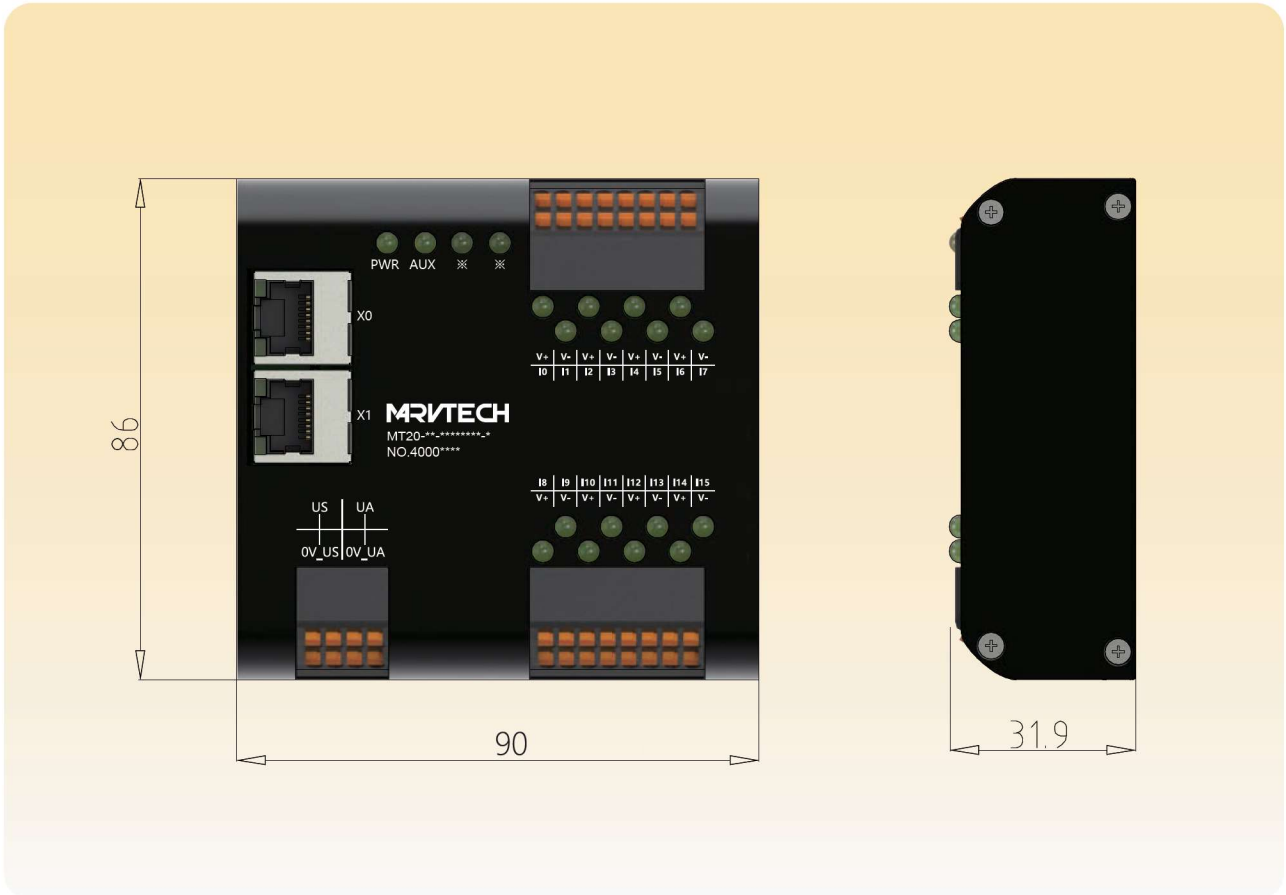

Basic parameters	
Housing material	Aluminum alloy
Housing color	Anodized black
Protection level	IP20
Dimensions (W x H x D)	86mm x 90mm x 31.9mm
Weight	301g
Operating temperature	-25°C...70°C
Storage temperature	-40°C...85°C
Operating humidity	5%...95%
Storage humidity	5%...95%
Operating Atmospheric pressure	80KPa...106KPa
Storage Atmospheric pressure	80KPa...106KPa
Application Environment	According to EN-61131
Vibration Test	According to IEC60068-2
Impact Test	According to IEC60068-27
EMC	According to IEC61000-4-2,-3,-4
Certification	CE,RoHS
Mounting Hole size	Rail installation



IP20-MT20-16 Fieldbus Module

Order Information				
Interface	Model	Order No.	Description	I/O Connection Type
	MT20-EC-DI16P	40000058	16 channel input, PNP IP20 Network Module	Terminal Connection, 8×2 Spring Terminals, max.1.5mm ²
	MT20-PN-DI16P	40000085		
	MT20-EI-DI16P	40000094		

Digital Input	
Ports	16
Connection	8×2 Spring Terminals,, max.1.5mm ²
Input Type	PNP
Diagnosis	Power supply short circuit diagnosis
Switch threshold	EN 61131-2 Type 1/3
Switch frequency	250 Hz

Module LED					
EtherCat		ProfiNet		EtherNet/IP	
PWR	GN: module power normally				
	RD: module power reverse				
I/O	GN: channel signal normally				
	RD: port power supply short circuit				
LINK	GN: Link normally				
	YE flash: link & data transmission normally				
	Light off: module unlinked				
RUN	GN: OP status	SF	RD: module fault	MS	GN: module work normally
	GN flash (slowly): SAFEOP status		RD: Internal error		GN flash: unconfigured / unlinked
	GN flash (quickly): Pre-OP status	BF	RD flash: device Name / IP error	NS	RD flash: device Name / IP error
	Light off: Init status		RD flash: device Name / IP error		GN: Network normally
ERR	RD flash: communication error			NS	GN flash: Network unlinked
	Light off: module work normally				RD flash: communication error

Pin Sequence (Power)	Pin Sequence (I/O)																																
	<table border="1"> <tr> <td>V+</td><td>V-</td><td>V+</td><td>V-</td><td>V+</td><td>V-</td><td>V+</td><td>V-</td> </tr> <tr> <td>I0</td><td>I1</td><td>I2</td><td>I3</td><td>I4</td><td>I5</td><td>I6</td><td>I7</td> </tr> </table> <table border="1"> <tr> <td>I8</td><td>I9</td><td>I10</td><td>I11</td><td>I12</td><td>I13</td><td>I14</td><td>I15</td> </tr> <tr> <td>V+</td><td>V-</td><td>V+</td><td>V-</td><td>V+</td><td>V-</td><td>V+</td><td>V-</td> </tr> </table>	V+	V-	V+	V-	V+	V-	V+	V-	I0	I1	I2	I3	I4	I5	I6	I7	I8	I9	I10	I11	I12	I13	I14	I15	V+	V-	V+	V-	V+	V-	V+	V-
V+	V-	V+	V-	V+	V-	V+	V-																										
I0	I1	I2	I3	I4	I5	I6	I7																										
I8	I9	I10	I11	I12	I13	I14	I15																										
V+	V-	V+	V-	V+	V-	V+	V-																										

Order Information				
Interface	Model	Order No.	Description	I/O Connection Type
	MT20-EC-DI16N	40000074	16 channel input, NPN IP20 Network Module	Terminal Connection, 8×2 Spring Terminals, max.1.5mm ²
	MT20-PN-DI16N	40000086		
	MT20-EI-DI16N	40000095		

Digital Input	
Ports	16
Connection	8×2 Spring Terminals,, max.1.5mm ²
Input Type	NPN
Diagnosis	Power supply short circuit diagnosis
Switch threshold	EN 61131-2 Type 1/3
Switch frequency	250 Hz

Module LED					
EtherCat		ProfiNet		EtherNet/IP	
PWR	GN: module power normally				
	RD: module power reverse				
I/O	GN: channel signal normally				
	RD: port power supply short circuit				
LINK	GN: Link normally				
	YE flash: link & data transmission normally				
	Light off: module unlinked				
RUN	GN: OP status	SF	RD: module fault	MS	GN: module work normally
	GN flash (slowly): SAFEOP status		RD: Internal error		GN flash: unconfigured / unlinked
	GN flash (quickly): Pre-OP status	BF	RD flash: device Name / IP error	NS	RD flash: device Name / IP error
	light off: Init status		RD flash: device Name / IP error		GN: Network normally
ERR	RD flash: communication error			NS	GN flash: Network unlinked
	Light off: module work normally				RD flash: communication error

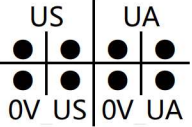
Pin Sequence (Power)	Pin Sequence (I/O)																																
	<table border="1"> <tr> <td>V+</td><td>V-</td><td>V+</td><td>V-</td><td>V+</td><td>V-</td><td>V+</td><td>V-</td> </tr> <tr> <td>10</td><td>11</td><td>12</td><td>13</td><td>14</td><td>15</td><td>16</td><td>17</td> </tr> </table> <table border="1"> <tr> <td>18</td><td>19</td><td>110</td><td>111</td><td>112</td><td>113</td><td>114</td><td>115</td> </tr> <tr> <td>V+</td><td>V-</td><td>V+</td><td>V-</td><td>V+</td><td>V-</td><td>V+</td><td>V-</td> </tr> </table>	V+	V-	V+	V-	V+	V-	V+	V-	10	11	12	13	14	15	16	17	18	19	110	111	112	113	114	115	V+	V-	V+	V-	V+	V-	V+	V-
V+	V-	V+	V-	V+	V-	V+	V-																										
10	11	12	13	14	15	16	17																										
18	19	110	111	112	113	114	115																										
V+	V-	V+	V-	V+	V-	V+	V-																										



IP20-MT20-16 Fieldbus Module

Order Information				
Interface	Model	Order No.	Description	I/O Connection Type
	MT20-EC-DO16P-0.5A	40000075	16 channel output, PNP IP20 Network Module	Terminal Connection, 8×2 Spring Terminals, max.1.5mm ²
	MT20-PN-DO16P-0.5A	40000087		
	MT20-EI-DO16P-0.5A	40000096		

Digital Output	
Ports	16
Connection	8×2 Spring Terminals,, max.1.5mm ²
Output Type	PNP
Diagnosis	point diagnosis
Sync. Factor	0V(potential group 24VDC)
Output Current	0.5A/ch
Load Type	Resistive, Inductive, Lamp

Module LED					
EtherCat		ProfiNet		EtherNet/IP	
PWR	GN: module power normally				
	RD: module power reverse				
I/O	GN: channel signal normally				
	RD: port power supply short circuit				
LINK	GN: Link normally				
	YE flash: link & data transmission normally				
	Light off: module unlinked				
RUN	GN: OP status	SF	RD: module fault	MS	GN: module work normally
	GN flash (slowly): SAFEOP status		RD: Internal error		GN flash: unconfigured / unlinked
	GN flash (quickly): Pre-OP status	BF	RD flash: device Name / IP error	NS	RD flash: device Name / IP error
	light off: Init status		RD flash: device Name / IP error		GN: Network normally
ERR	RD flash: communication error			NS	GN flash: Network unlinked
	Light off: module work normally				RD flash: communication error

Pin Sequence (Power)	Pin Sequence (I/O)																																
	<table border="1"> <tr> <td>V-</td><td>V-</td><td>V-</td><td>V-</td><td>V-</td><td>V-</td><td>V-</td><td>V-</td> </tr> <tr> <td>00</td><td>01</td><td>02</td><td>03</td><td>04</td><td>05</td><td>06</td><td>07</td> </tr> </table> <table border="1"> <tr> <td>08</td><td>09</td><td>010</td><td>011</td><td>012</td><td>013</td><td>014</td><td>015</td> </tr> <tr> <td>V-</td><td>V-</td><td>V-</td><td>V-</td><td>V-</td><td>V-</td><td>V-</td><td>V-</td> </tr> </table>	V-	V-	V-	V-	V-	V-	V-	V-	00	01	02	03	04	05	06	07	08	09	010	011	012	013	014	015	V-	V-	V-	V-	V-	V-	V-	V-
V-	V-	V-	V-	V-	V-	V-	V-																										
00	01	02	03	04	05	06	07																										
08	09	010	011	012	013	014	015																										
V-	V-	V-	V-	V-	V-	V-	V-																										

Order Information				
Interface	Model	Order No.	Description	I/O Connection Type
	MT20-EC-DO16N-0.5A	40000076	16 channel output, NPN IP20 Network Module	Terminal Connection, 8×2 Spring Terminals, max.1.5mm ²
	MT20-PN-DO16N-0.5A	40000088		
	MT20-EI-DO16N-0.5A	40000097		

Digital Output	
Ports	16
Connection	8×2 Spring Terminals,, max.1.5mm ²
Output Type	NPN
Diagnosis	point diagnosis
Sync. Factor	0V(potential group 24VDC)
Output Current	0.5A/ch
Load Type	Resistive, Inductive, Lamp

Module LED					
EtherCat		ProfiNet		EtherNet/IP	
PWR	GN: module power normally				
	RD: module power reverse				
I/O	GN: channel signal normally				
	RD: port power supply short circuit				
LINK	GN: Link normally				
	YE flash: link & data transmission normally				
	Light off: module unlinked				
RUN	GN: OP status	SF	RD: module fault	MS	GN: module work normally
	GN flash (slowly): SAFEOP status		RD: Internal error		GN flash: unconfigured / unlinked
	GN flash (quickly): Pre-OP status	BF	RD flash: device Name / IP error	NS	RD flash: device Name / IP error
	light off: Init status		RD flash: device Name / IP error		GN: Network normally
ERR	RD flash: communication error			NS	GN flash: Network unlinked
	Light off: module work normally				RD flash: communication error

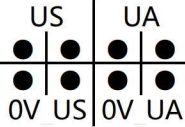
Pin Sequence (Power)	Pin Sequence (I/O)																																
	<table border="1"> <tr> <td>V+</td><td>V+</td><td>V+</td><td>V+</td><td>V+</td><td>V+</td><td>V+</td><td>V+</td> </tr> <tr> <td>00</td><td>01</td><td>02</td><td>03</td><td>04</td><td>05</td><td>06</td><td>07</td> </tr> </table> <table border="1"> <tr> <td>08</td><td>09</td><td>010</td><td>011</td><td>012</td><td>013</td><td>014</td><td>015</td> </tr> <tr> <td>V+</td><td>V+</td><td>V+</td><td>V+</td><td>V+</td><td>V+</td><td>V+</td><td>V+</td> </tr> </table>	V+	V+	V+	V+	V+	V+	V+	V+	00	01	02	03	04	05	06	07	08	09	010	011	012	013	014	015	V+	V+	V+	V+	V+	V+	V+	V+
V+	V+	V+	V+	V+	V+	V+	V+																										
00	01	02	03	04	05	06	07																										
08	09	010	011	012	013	014	015																										
V+	V+	V+	V+	V+	V+	V+	V+																										

IP20-MT20-16 Fieldbus Module



Order Information				
Interface	Model	Order No.	Description	I/O Connection Type
	MT20-EC-DIO16P-0.5A	40000077	16 channel, PNP adaptive input/output, IP20 Network Module	Terminal Connection, 8×2 Spring Terminals, max.1.5mm ²
	MT20-PN-DIO16P-0.5A	40000089		
	MT20-EI-DIO16P-0.5A	40000098		

Digital Input	
Ports	16
Connection	8×2 Spring Terminals,, max.1.5mm ²
Input Type	PNP
Diagnosis	Power supply short circuit diagnosis
Switch threshold	EN 61131-2 Type 1/3
Switch frequency	250 Hz

Digital Output	
Ports	16
Connection	8×2 Spring Terminals,, max.1.5mm ²
Output Type	PNP
Diagnosis	point diagnosis
Sync. Factor	0V(potential group 24VDC)
Output Current	0.5A/ch
Load Type	Resistive, Inductive, Lamp

Module LED					
EtherCat		ProfiNet		EtherNet/IP	
PWR	GN: module power normally				
	RD: module power reverse				
I/O	GN: channel signal normally				
	RD: port power supply short circuit				
LINK	GN: Link normally				
	YE flash: link & data transmission normally				
	Light off: module unlinked				
RUN	GN: OP status	SF	RD: module fault	MS	GN: module work normally
	GN flash (slowly): SAFEOP status		RD: Internal error		GN flash: unconfigured / unlinked
	GN flash (quickly): Pre-OP status	BF	RD flash: device Name / IP error	NS	RD flash: device Name / IP error
	Light off: Init status		RD flash: device Name / IP error		GN: Network normally
ERR	RD flash: communication error			NS	GN flash: Network unlinked
	Light off: module work normally				RD flash: communication error

Pin Sequence (Power)	Pin Sequence (I/O)																																
	<table border="1"> <tr> <td>V+</td><td>V-</td><td>V+</td><td>V-</td><td>V+</td><td>V-</td><td>V+</td><td>V-</td> </tr> <tr> <td>IO0</td><td>IO1</td><td>IO2</td><td>IO3</td><td>IO4</td><td>IO5</td><td>IO6</td><td>IO7</td> </tr> </table> <table border="1"> <tr> <td>IO8</td><td>IO9</td><td>IO10</td><td>IO11</td><td>IO12</td><td>IO13</td><td>IO14</td><td>IO15</td> </tr> <tr> <td>V+</td><td>V-</td><td>V+</td><td>V-</td><td>V+</td><td>V-</td><td>V+</td><td>V-</td> </tr> </table>	V+	V-	V+	V-	V+	V-	V+	V-	IO0	IO1	IO2	IO3	IO4	IO5	IO6	IO7	IO8	IO9	IO10	IO11	IO12	IO13	IO14	IO15	V+	V-	V+	V-	V+	V-	V+	V-
V+	V-	V+	V-	V+	V-	V+	V-																										
IO0	IO1	IO2	IO3	IO4	IO5	IO6	IO7																										
IO8	IO9	IO10	IO11	IO12	IO13	IO14	IO15																										
V+	V-	V+	V-	V+	V-	V+	V-																										

Order Information				
Interface	Model	Order No.	Description	I/O Connection Type
	MT20-EC-DIO16N-0.5A	40000078	16 channel, NPN adaptive input/output, IP20 Network Module	Terminal Connection, 8×2 Spring Terminals, max.1.5mm ²
	MT20-PN-DIO16N-0.5A	40000090		
	MT20-EI-DIO16N-0.5A	40000099		

Digital Input	
Ports	16
Connection	8×2 Spring Terminals,, max.1.5mm ²
Input Type	NPN
Diagnosis	Power supply short circuit diagnosis
Switch threshold	EN 61131-2 Type 1/3
Switch frequency	250 Hz

Digital Output	
Ports	16
Connection	8×2 Spring Terminals,, max.1.5mm ²
Output Type	NPN
Diagnosis	point diagnosis
Sync. Factor	0V(potential group 24VDC)
Output Current	0.5A/ch
Load Type	Resistive, Inductive, Lamp

Module LED					
EtherCat		ProfiNet		EtherNet/IP	
PWR	GN: module power normally				
	RD: module power reverse				
I/O	GN: channel signal normally				
	RD: port power supply short circuit				
LINK	GN: Link normally				
	YE flash: link & data transmission normally				
	Light off: module unlinked				
RUN	GN: OP status	SF	RD: module fault	MS	GN: module work normally
	GN flash (slowly): SAFEOP status		RD: Internal error		GN flash: unconfigured / unlinked
	GN flash (quickly): Pre-OP status	BF	RD flash: device Name / IP error	NS	RD flash: device Name / IP error
	Light off: Init status		RD flash: device Name / IP error		GN: Network normally
ERR	RD flash: communication error			NS	GN flash: Network unlinked
	Light off: module work normally				RD flash: communication error

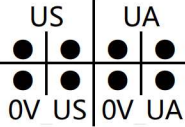
Pin Sequence (Power)	Pin Sequence (I/O)																																								
	<table border="1"> <tr> <td>V+</td><td>V-</td><td>V+</td><td>V-</td><td>V+</td><td>V-</td><td>V+</td><td>V-</td> </tr> <tr> <td>IO0</td><td>IO1</td><td>IO2</td><td>IO3</td><td>IO4</td><td>IO5</td><td>IO6</td><td>IO7</td> </tr> <tr> <td colspan="8"> </td> </tr> <tr> <td>IO8</td><td>IO9</td><td>IO10</td><td>IO11</td><td>IO12</td><td>IO13</td><td>IO14</td><td>IO15</td> </tr> <tr> <td>V+</td><td>V-</td><td>V+</td><td>V-</td><td>V+</td><td>V-</td><td>V+</td><td>V-</td> </tr> </table>	V+	V-	V+	V-	V+	V-	V+	V-	IO0	IO1	IO2	IO3	IO4	IO5	IO6	IO7									IO8	IO9	IO10	IO11	IO12	IO13	IO14	IO15	V+	V-	V+	V-	V+	V-	V+	V-
V+	V-	V+	V-	V+	V-	V+	V-																																		
IO0	IO1	IO2	IO3	IO4	IO5	IO6	IO7																																		
IO8	IO9	IO10	IO11	IO12	IO13	IO14	IO15																																		
V+	V-	V+	V-	V+	V-	V+	V-																																		

IP20-MT20-16 Fieldbus Module



Order Information				
Interface	Model	Order No.	Description	I/O Connection Type
	MT20-EC-DI8PDO8P-0.5A	40000040	8 channel input, PNP 8 channel output, PNP IP20 Network Module	Terminal Connection, 8×2 Spring Terminals, max.1.5mm ²
	MT20-PN-DI8PDO8P-0.5A	40000036		
	MT20-EI-DI8PDO8P-0.5A	40000041		

Digital Input	
Ports	8
Connection	8×2 Spring Terminals,, max.1.5mm ²
Input Type	PNP
Diagnosis	Power supply short circuit diagnosis
Switch threshold	EN 61131-2 Type 1/3
Switch frequency	250 Hz

Digital Output	
Ports	8
Connection	8×2 Spring Terminals,, max.1.5mm ²
Output Type	PNP
Diagnosis	point diagnosis
Sync. Factor	0V(potential group 24VDC)
Output Current	0.5A/ch
Load Type	Resistive, Inductive, Lamp

Module LED					
EtherCat		ProfiNet		EtherNet/IP	
PWR	GN: module power normally				
	RD: module power reverse				
I/O	GN: channel signal normally				
	RD: port power supply short circuit				
LINK	GN: Link normally				
	YE flash: link & data transmission normally				
	Light off: module unlinked				
RUN	GN: OP status	SF	RD: module fault	MS	GN: module work normally
	GN flash (slowly): SAFEOP status		RD: Internal error		GN flash: unconfigured / unlinked
	GN flash (quickly): Pre-OP status	BF	RD flash: device Name / IP error	NS	RD flash: device Name / IP error
	Light off: Init status		RD flash: device Name / IP error		GN: Network normally
ERR	RD flash: communication error			NS	GN flash: Network unlinked
	Light off: module work normally				RD flash: communication error

Pin Sequence (Power)	Pin Sequence (I/O)																																
	<table border="1"> <tr> <td>V+</td><td>V-</td><td>V+</td><td>V-</td><td>V+</td><td>V-</td><td>V+</td><td>V-</td> </tr> <tr> <td>I0</td><td>I1</td><td>I2</td><td>I3</td><td>I4</td><td>I5</td><td>I6</td><td>I7</td> </tr> </table> <table border="1"> <tr> <td>O0</td><td>O1</td><td>O2</td><td>O3</td><td>O4</td><td>O5</td><td>O6</td><td>O7</td> </tr> <tr> <td>V-</td><td>V-</td><td>V-</td><td>V-</td><td>V-</td><td>V-</td><td>V-</td><td>V-</td> </tr> </table>	V+	V-	V+	V-	V+	V-	V+	V-	I0	I1	I2	I3	I4	I5	I6	I7	O0	O1	O2	O3	O4	O5	O6	O7	V-	V-	V-	V-	V-	V-	V-	V-
V+	V-	V+	V-	V+	V-	V+	V-																										
I0	I1	I2	I3	I4	I5	I6	I7																										
O0	O1	O2	O3	O4	O5	O6	O7																										
V-	V-	V-	V-	V-	V-	V-	V-																										

Order Information				
Interface	Model	Order No.	Description	I/O Connection Type
	MT20-EC-DI8NDO8N-0.5A	40000286	8 channel input, NPN 8 channel output, NPN IP20 Network Module	Terminal Connection, 8×2 Spring Terminals, max.1.5mm ²
	MT20-PN-DI8NDO8N-0.5A	40000287		
	MT20-EI-DI8NDO8N-0.5A	40000288		

Digital Input	
Ports	8
Connection	8×2 Spring Terminals,, max.1.5mm ²
Input Type	NPN
Diagnosis	Power supply short circuit diagnosis
Switch threshold	EN 61131-2 Type 1/3
Switch frequency	250 Hz

Digital Output	
Ports	8
Connection	8×2 Spring Terminals,, max.1.5mm ²
Output Type	NPN
Diagnosis	point diagnosis
Sync. Factor	0V(potential group 24VDC)
Output Current	0.5A/ch
Load Type	Resistive, Inductive, Lamp

Module LED					
EtherCat		ProfiNet		EtherNet/IP	
PWR	GN: module power normally				
	RD: module power reverse				
I/O	GN: channel signal normally				
	RD: port power supply short circuit				
LINK	GN: Link normally				
	YE flash: link & data transmission normally				
	Light off: module unlinked				
RUN	GN: OP status	SF	RD: module fault	MS	GN: module work normally
	GN flash (slowly): SAFEOP status		RD: Internal error		GN flash: unconfigured / unlinked
	GN flash (quickly): Pre-OP status	BF	RD flash: device Name / IP error	NS	RD flash: device Name / IP error
	light off: Init status		RD flash: device Name / IP error		GN: Network normally
ERR	RD flash: communication error			NS	GN flash: Network unlinked
	Light off: module work normally				RD flash: communication error

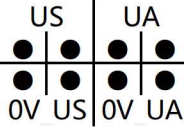
Pin Sequence (Power)	Pin Sequence (I/O)																																
	<table border="1"> <tr> <td>V+</td><td>V-</td><td>V+</td><td>V-</td><td>V+</td><td>V-</td><td>V+</td><td>V-</td> </tr> <tr> <td>I0</td><td>I1</td><td>I2</td><td>I3</td><td>I4</td><td>I5</td><td>I6</td><td>I7</td> </tr> </table> <table border="1"> <tr> <td>O0</td><td>O1</td><td>O2</td><td>O3</td><td>O4</td><td>O5</td><td>O6</td><td>O7</td> </tr> <tr> <td>V+</td><td>V+</td><td>V+</td><td>V+</td><td>V+</td><td>V+</td><td>V+</td><td>V+</td> </tr> </table>	V+	V-	V+	V-	V+	V-	V+	V-	I0	I1	I2	I3	I4	I5	I6	I7	O0	O1	O2	O3	O4	O5	O6	O7	V+	V+	V+	V+	V+	V+	V+	V+
V+	V-	V+	V-	V+	V-	V+	V-																										
I0	I1	I2	I3	I4	I5	I6	I7																										
O0	O1	O2	O3	O4	O5	O6	O7																										
V+	V+	V+	V+	V+	V+	V+	V+																										



**IP20 MT20-32
Network Module**

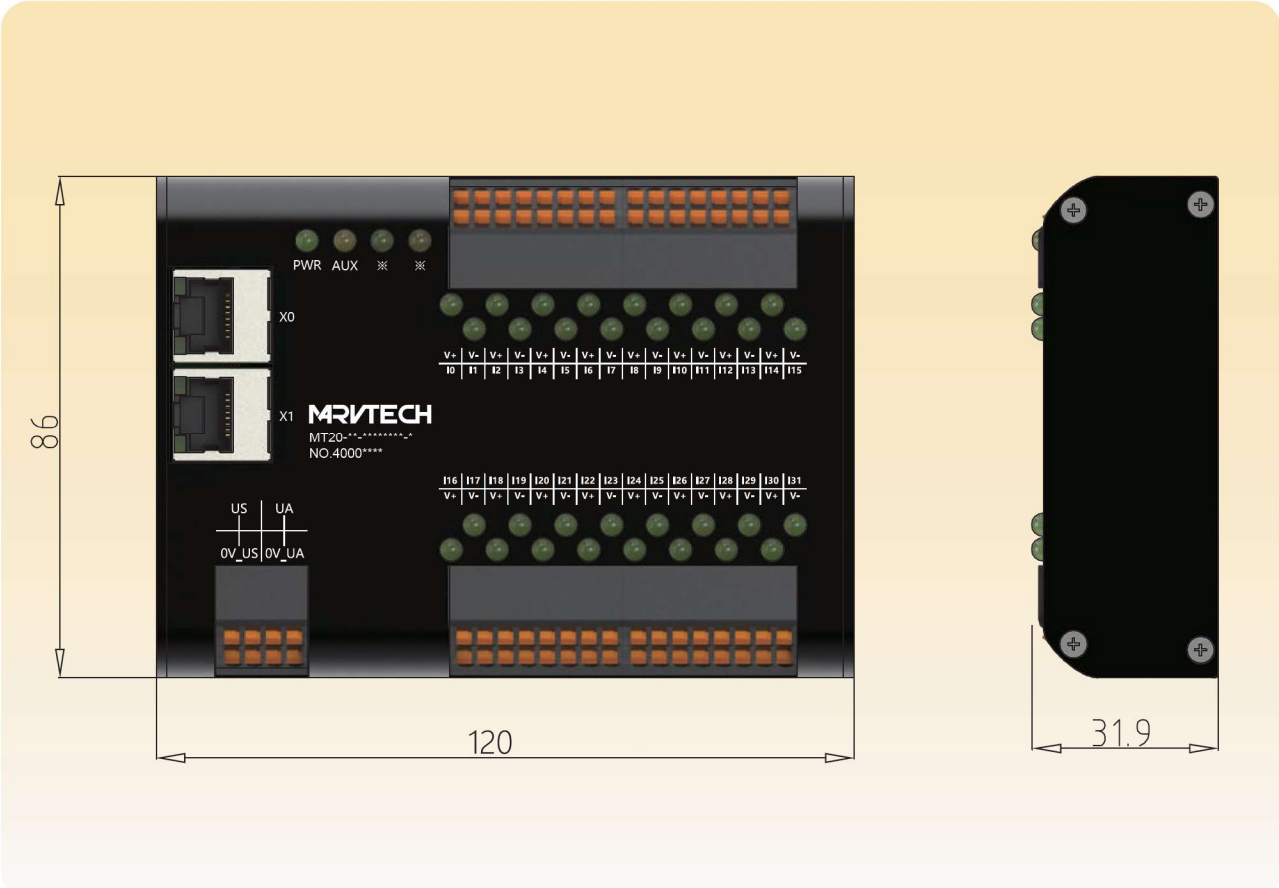

Basic parameters	
Housing material	Aluminum alloy
Housing color	Anodized black
Protection level	IP20
Dimensions (W x H x D)	86mm x 120mm x 31.9mm
Weight	429g
Operating temperature	-25°C...70°C
Storage temperature	-40°C...85°C
Operating humidity	5%...95%
Storage humidity	5%...95%
Operating Atmospheric pressure	80KPa...106KPa
Storage Atmospheric pressure	80KPa...106KPa
Application Environment	According to EN-61131
Vibration Test	According to IEC60068-2
Impact Test	According to IEC60068-27
EMC	According to IEC61000-4-2,-3,-4
Certification	CE,RoHS
Mounting Hole size	Rail installation



IP20-MT20-32 Fieldbus Module

Order Information				
Interface	Model	Order No.	Description	I/O Connection Type
	MT20-EC-DI32P	40000079	32 channel input, PNP IP20 individual module	Terminal Connection, 16×2 Spring Terminals, max.1.5mm ²
	MT20-PN-DI32P	40000060		
	MT20-EI-DI32P	40000100		

Digital Input	
Ports	32
Connection	16×2 Spring Terminals, max.1.5mm ²
Input Type	PNP
Diagnosis	Power supply short circuit diagnosis
On-off Threshold	EN 61131-2 Type 1/3
On-off Frequency	250 Hz

Module LED					
EtherCat		ProfiNet		EtherNet/IP	
PWR	GN: module power normally				
	RD: module power reverse				
I/O	GN: channel signal normally				
	RD: port power supply short circuit				
LINK	GN: Link normally				
	YE flash: link & data transmission normally				
	Light off: module unlinked				
RUN	GN: OP status	SF	RD: module fault	MS	GN: module work normally
	GN flash (slowly): SAFEOP status		RD: Internal error		GN flash: unconfigured / unlinked
	GN flash (quickly): Pre-OP status	BF	RD flash: device Name / IP error	NS	RD flash: device Name / IP error
	Light off: Init status		RD flash: device Name / IP error		GN: Network normally
ERR	RD flash: communication error			NS	GN flash: Network unlinked
	Light off: module work normally				RD flash: communication error

Pin Sequence (Power)	Pin Sequence (I/O)																																																																				
	<table border="1"> <tr> <td>V+</td><td>V-</td><td>V+</td><td>V-</td><td>V+</td><td>V-</td><td>V+</td><td>V-</td><td>V+</td><td>V-</td><td>V+</td><td>V-</td><td>V+</td><td>V-</td><td>V+</td><td>V-</td><td>V+</td><td>V-</td> </tr> <tr> <td>10</td><td>11</td><td>12</td><td>13</td><td>14</td><td>15</td><td>16</td><td>17</td><td>18</td><td>19</td><td>110</td><td>111</td><td>112</td><td>113</td><td>114</td><td>115</td><td></td><td></td> </tr> </table> <table border="1"> <tr> <td>116</td><td>117</td><td>118</td><td>119</td><td>120</td><td>121</td><td>122</td><td>123</td><td>124</td><td>125</td><td>126</td><td>127</td><td>128</td><td>129</td><td>130</td><td>131</td> </tr> <tr> <td>V+</td><td>V-</td><td>V+</td><td>V-</td><td>V+</td><td>V-</td><td>V+</td><td>V-</td><td>V+</td><td>V-</td><td>V+</td><td>V-</td><td>V+</td><td>V-</td><td>V+</td><td>V-</td> </tr> </table>	V+	V-	V+	V-	V+	V-	V+	V-	V+	V-	V+	V-	V+	V-	V+	V-	V+	V-	10	11	12	13	14	15	16	17	18	19	110	111	112	113	114	115			116	117	118	119	120	121	122	123	124	125	126	127	128	129	130	131	V+	V-	V+	V-	V+	V-	V+	V-	V+	V-	V+	V-	V+	V-	V+	V-
V+	V-	V+	V-	V+	V-	V+	V-	V+	V-	V+	V-	V+	V-	V+	V-	V+	V-																																																				
10	11	12	13	14	15	16	17	18	19	110	111	112	113	114	115																																																						
116	117	118	119	120	121	122	123	124	125	126	127	128	129	130	131																																																						
V+	V-	V+	V-	V+	V-	V+	V-	V+	V-	V+	V-	V+	V-	V+	V-																																																						

Order Information				
Interface	Model	Order No.	Description	I/O Connection Type
	MT20-EC-DI32N	40000081	32 channel input, NPN IP20 individual module	Terminal Connection, 16×2 Spring Terminals, max.1.5mm ²
	MT20-PN-DI32N	40000092		
	MT20-EI-DI32N	40000102		

Digital Input	
Ports	32
Connection	16×2 Spring Terminals, max.1.5mm ²
Input Type	NPN
Diagnosis	Power supply short circuit diagnosis
On-off Threshold	EN 61131-2 Type 1/3
On-off Frequency	250 Hz

Module LED					
EtherCat		ProfiNet		EtherNet/IP	
PWR	GN: module power normally				
	RD: module power reverse				
I/O	GN: channel signal normally				
	RD: port power supply short circuit				
LINK	GN: Link normally				
	YE flash: link & data transmission normally				
	Light off: module unlinked				
RUN	GN: OP status	SF	RD: module fault	MS	GN: module work normally
	GN flash (slowly): SAFEOP status		RD: Internal error		GN flash: unconfigured / unlinked
	GN flash (quickly): Pre-OP status	BF	RD flash: device Name / IP error	NS	RD flash: device Name / IP error
	Light off: Init status		RD flash: device Name / IP error		GN: Network normally
ERR	RD flash: communication error			NS	GN flash: Network unlinked
	Light off: module work normally				RD flash: communication error

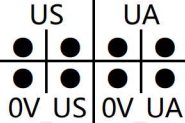
Pin Sequence (Power)	Pin Sequence (I/O)																																																																				
	<table border="1"> <tr> <td>V+</td><td>V-</td><td>V+</td><td>V-</td><td>V+</td><td>V-</td><td>V+</td><td>V-</td><td>V+</td><td>V-</td><td>V+</td><td>V-</td><td>V+</td><td>V-</td><td>V+</td><td>V-</td><td>V+</td><td>V-</td> </tr> <tr> <td>10</td><td>11</td><td>12</td><td>13</td><td>14</td><td>15</td><td>16</td><td>17</td><td>18</td><td>19</td><td>110</td><td>111</td><td>112</td><td>113</td><td>114</td><td>115</td><td></td><td></td> </tr> </table> <table border="1"> <tr> <td>116</td><td>117</td><td>118</td><td>119</td><td>120</td><td>121</td><td>122</td><td>123</td><td>124</td><td>125</td><td>126</td><td>127</td><td>128</td><td>129</td><td>130</td><td>131</td> </tr> <tr> <td>V+</td><td>V-</td><td>V+</td><td>V-</td><td>V+</td><td>V-</td><td>V+</td><td>V-</td><td>V+</td><td>V-</td><td>V+</td><td>V-</td><td>V+</td><td>V-</td><td>V+</td><td>V-</td> </tr> </table>	V+	V-	V+	V-	V+	V-	V+	V-	V+	V-	V+	V-	V+	V-	V+	V-	V+	V-	10	11	12	13	14	15	16	17	18	19	110	111	112	113	114	115			116	117	118	119	120	121	122	123	124	125	126	127	128	129	130	131	V+	V-	V+	V-	V+	V-	V+	V-	V+	V-	V+	V-	V+	V-	V+	V-
V+	V-	V+	V-	V+	V-	V+	V-	V+	V-	V+	V-	V+	V-	V+	V-	V+	V-																																																				
10	11	12	13	14	15	16	17	18	19	110	111	112	113	114	115																																																						
116	117	118	119	120	121	122	123	124	125	126	127	128	129	130	131																																																						
V+	V-	V+	V-	V+	V-	V+	V-	V+	V-	V+	V-	V+	V-	V+	V-																																																						



IP20-MT20-32 Fieldbus Module

Order Information				
Interface	Model	Order No.	Description	I/O Connection Type
	MT20-EC-DO32P-0.5A	40000080	32 channel output, PNP IP20 individual module	Terminal Connection, 16×2 Spring Terminals, max.1.5mm ²
	MT20-PN-DO32P-0.5A	40000091		
	MT20-EI-DO32P-0.5A	40000101		

Digital Output	
Ports	32
Connection	16×2 Spring Terminals, max.1.5mm ²
Output Type	PNP
Diagnosis	point diagnosis
Sync. Factor	0V(potential group 24VDC)
Output Current	0.5A/ch
Load Type	Resistive, Inductive, Lamp

Module LED					
EtherCat		ProfiNet		EtherNet/IP	
PWR	GN: module power normally				
	RD: module power reverse				
I/O	GN: channel signal normally				
	RD: port power supply short circuit				
LINK	GN: Link normally				
	YE flash: link & data transmission normally				
	Light off: module unlinked				
RUN	GN: OP status	SF	RD: module fault	MS	GN: module work normally
	GN flash (slowly): SAFEOP status		RD: Internal error		GN flash: unconfigured / unlinked
	GN flash (quickly): Pre-OP status	BF	RD flash: device Name / IP error	NS	RD flash: device Name / IP error
	Light off: Init status		RD flash: device Name / IP error		GN: Network normally
ERR	RD flash: communication error			NS	GN flash: Network unlinked
	Light off: module work normally				RD flash: communication error

Pin Sequence (Power)	Pin Sequence (I/O)																																																																																	
	<table border="1"> <tr> <td>V-</td><td>V-</td><td>V-</td><td>V-</td><td>V-</td><td>V-</td><td>V-</td><td>V-</td><td>V-</td><td>V-</td><td>V-</td><td>V-</td><td>V-</td><td>V-</td><td>V-</td><td>V-</td><td>V-</td> </tr> <tr> <td>00</td><td>01</td><td>02</td><td>03</td><td>04</td><td>05</td><td>06</td><td>07</td><td>08</td><td>09</td><td>10</td><td>11</td><td>12</td><td>13</td><td>14</td><td>15</td> </tr> <tr> <td colspan="16"> </td> </tr> <tr> <td>016</td><td>017</td><td>018</td><td>019</td><td>020</td><td>021</td><td>022</td><td>023</td><td>024</td><td>025</td><td>026</td><td>027</td><td>028</td><td>029</td><td>030</td><td>031</td> </tr> <tr> <td>V-</td><td>V-</td><td>V-</td><td>V-</td><td>V-</td><td>V-</td><td>V-</td><td>V-</td><td>V-</td><td>V-</td><td>V-</td><td>V-</td><td>V-</td><td>V-</td><td>V-</td><td>V-</td> </tr> </table>	V-	V-	V-	V-	V-	V-	V-	V-	V-	V-	V-	V-	V-	V-	V-	V-	V-	00	01	02	03	04	05	06	07	08	09	10	11	12	13	14	15																	016	017	018	019	020	021	022	023	024	025	026	027	028	029	030	031	V-	V-	V-	V-	V-	V-	V-	V-	V-	V-	V-	V-	V-	V-	V-	V-
V-	V-	V-	V-	V-	V-	V-	V-	V-	V-	V-	V-	V-	V-	V-	V-	V-																																																																		
00	01	02	03	04	05	06	07	08	09	10	11	12	13	14	15																																																																			
016	017	018	019	020	021	022	023	024	025	026	027	028	029	030	031																																																																			
V-	V-	V-	V-	V-	V-	V-	V-	V-	V-	V-	V-	V-	V-	V-	V-																																																																			

Order Information				
Interface	Model	Order No.	Description	I/O Connection Type
	MT20-EC-DO32N-0.5A	40000082	32 channel output, NPN IP20 individual module	Terminal Connection, 16×2 Spring Terminals, max.1.5mm ²
	MT20-PN-DO32N-0.5A	40000061		
	MT20-EI-DO32N-0.5A	40000103		

Digital Output	
Ports	32
Connection	16×2 Spring Terminals, max.1.5mm ²
Output Type	NPN
Diagnosis	point diagnosis
Sync. Factor	0V(potential group 24VDC)
Output Current	0.5A/ch
Load Type	Resistive, Inductive, Lamp

Module LED					
EtherCat		ProfiNet		EtherNet/IP	
PWR	GN: module power normally				
	RD: module power reverse				
I/O	GN: channel signal normally				
	RD: port power supply short circuit				
LINK	GN: Link normally				
	YE flash: link & data transmission normally				
	Light off: module unlinked				
RUN	GN: OP status	SF	RD: module fault	MS	GN: module work normally
	GN flash (slowly): SAFEOP status		RD: Internal error		GN flash: unconfigured / unlinked
	GN flash (quickly): Pre-OP status	BF	RD flash: device Name / IP error	NS	RD flash: device Name / IP error
	light off: Init status		RD flash: device Name / IP error		GN: Network normally
ERR	RD flash: communication error			NS	GN flash: Network unlinked
	Light off: module work normally				RD flash: communication error

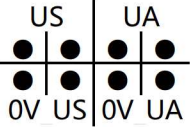
Pin Sequence (Power)	Pin Sequence (I/O)																																																																								
	<table border="1"> <tr> <td>V+</td><td>V+</td><td>V+</td><td>V+</td><td>V+</td><td>V+</td><td>V+</td><td>V+</td><td>V+</td><td>V+</td><td>V+</td><td>V+</td><td>V+</td><td>V+</td><td>V+</td><td>V+</td><td>V+</td><td>V+</td> </tr> <tr> <td>00</td><td>01</td><td>02</td><td>03</td><td>04</td><td>05</td><td>06</td><td>07</td><td>08</td><td>09</td><td>10</td><td>11</td><td>12</td><td>13</td><td>14</td><td>15</td><td></td><td></td> </tr> <tr> <td>016</td><td>017</td><td>018</td><td>019</td><td>020</td><td>021</td><td>022</td><td>023</td><td>024</td><td>025</td><td>026</td><td>027</td><td>028</td><td>029</td><td>030</td><td>031</td><td></td><td></td> </tr> <tr> <td>V+</td><td>V+</td><td>V+</td><td>V+</td><td>V+</td><td>V+</td><td>V+</td><td>V+</td><td>V+</td><td>V+</td><td>V+</td><td>V+</td><td>V+</td><td>V+</td><td>V+</td><td>V+</td><td></td><td></td> </tr> </table>	V+	V+	V+	V+	V+	V+	V+	V+	V+	V+	V+	V+	V+	V+	V+	V+	V+	V+	00	01	02	03	04	05	06	07	08	09	10	11	12	13	14	15			016	017	018	019	020	021	022	023	024	025	026	027	028	029	030	031			V+	V+	V+	V+	V+	V+	V+	V+	V+	V+	V+	V+	V+	V+	V+	V+		
V+	V+	V+	V+	V+	V+	V+	V+	V+	V+	V+	V+	V+	V+	V+	V+	V+	V+																																																								
00	01	02	03	04	05	06	07	08	09	10	11	12	13	14	15																																																										
016	017	018	019	020	021	022	023	024	025	026	027	028	029	030	031																																																										
V+	V+	V+	V+	V+	V+	V+	V+	V+	V+	V+	V+	V+	V+	V+	V+																																																										

IP20-MT20-32 Fieldbus Module



Order Information				
Interface	Model	Order No.	Description	I/O Connection Type
	MT20-EC-DI16PDO16P-0.5A	40000083	16 channel input, PNP 16 channel output, PNP IP20 individual module	Terminal Connection, 16×2 Spring Terminals, max.1.5mm ²
	MT20-PN-DI16PDO16P-0.5A	40000059		
	MT20-EI-DI16PDO16P-0.5A	40000104		

Digital Input	
Ports	16
Connection	8×2 Spring Terminals,, max.1.5mm ²
Input Type	PNP
Diagnosis	Power supply short circuit diagnosis
Switch threshold	EN 61131-2 Type 1/3
Switch frequency	250 Hz

Digital Output	
Ports	16
Connection	8×2 Spring Terminals,, max.1.5mm ²
Output Type	PNP
Diagnosis	point diagnosis
Sync. Factor	0V(potential group 24VDC)
Output Current	0.5A/ch
Load Type	Resistive, Inductive, Lamp

Module LED					
EtherCat		ProfiNet		EtherNet/IP	
PWR	GN: module power normally				
	RD: module power reverse				
I/O	GN: channel signal normally				
	RD: port power supply short circuit				
LINK	GN: Link normally				
	YE flash: link & data transmission normally				
	Light off: module unlinked				
RUN	GN: OP status	SF	RD: module fault	MS	GN: module work normally
	GN flash (slowly): SAFEOP status		RD: Internal error		GN flash: unconfigured / unlinked
	GN flash (quickly): Pre-OP status	BF	RD flash: device Name / IP error	NS	RD flash: device Name / IP error
	light off: Init status		RD flash: device Name / IP error		GN: Network normally
ERR	RD flash: communication error			NS	GN flash: Network unlinked
	Light off: module work normally				RD flash: communication error

Pin Sequence (Power)	Pin Sequence (I/O)																																																																				
	<table border="1"> <tr> <td>V+</td><td>V-</td><td>V+</td><td>V-</td><td>V+</td><td>V-</td><td>V+</td><td>V-</td><td>V+</td><td>V-</td><td>V+</td><td>V-</td><td>V+</td><td>V-</td><td>V+</td><td>V-</td><td>V+</td><td>V-</td> </tr> <tr> <td>10</td><td>11</td><td>12</td><td>13</td><td>14</td><td>15</td><td>16</td><td>17</td><td>18</td><td>19</td><td>110</td><td>111</td><td>112</td><td>113</td><td>114</td><td>115</td><td></td><td></td> </tr> </table> <table border="1"> <tr> <td>00</td><td>01</td><td>02</td><td>03</td><td>04</td><td>05</td><td>06</td><td>07</td><td>08</td><td>09</td><td>010</td><td>011</td><td>012</td><td>013</td><td>014</td><td>015</td> </tr> <tr> <td>V-</td><td>V-</td><td>V-</td><td>V-</td><td>V-</td><td>V-</td><td>V-</td><td>V-</td><td>V-</td><td>V-</td><td>V-</td><td>V-</td><td>V-</td><td>V-</td><td>V-</td><td>V-</td> </tr> </table>	V+	V-	V+	V-	V+	V-	V+	V-	V+	V-	V+	V-	V+	V-	V+	V-	V+	V-	10	11	12	13	14	15	16	17	18	19	110	111	112	113	114	115			00	01	02	03	04	05	06	07	08	09	010	011	012	013	014	015	V-	V-	V-	V-	V-	V-	V-	V-	V-	V-	V-	V-	V-	V-	V-	V-
V+	V-	V+	V-	V+	V-	V+	V-	V+	V-	V+	V-	V+	V-	V+	V-	V+	V-																																																				
10	11	12	13	14	15	16	17	18	19	110	111	112	113	114	115																																																						
00	01	02	03	04	05	06	07	08	09	010	011	012	013	014	015																																																						
V-	V-	V-	V-	V-	V-	V-	V-	V-	V-	V-	V-	V-	V-	V-	V-																																																						

Order Information				
Interface	Model	Order No.	Description	I/O Connection Type
	MT20-EC-DI16NDO16N-0.5A	40000084	16 channel input, NPN 16 channel output, NPN IP20 individual module	Terminal Connection, 16×2 Spring Terminals, max.1.5mm ²
	MT20-PN-DI16NDO16N-0.5A	40000093		
	MT20-EI-DI16NDO16N-0.5A	40000105		

Digital Input	
Ports	16
Connection	8×2 Spring Terminals,, max.1.5mm ²
Input Type	NPN
Diagnosis	Power supply short circuit diagnosis
Switch threshold	EN 61131-2 Type 1/3
Switch frequency	250 Hz

Digital Output	
Ports	16
Connection	8×2 Spring Terminals,, max.1.5mm ²
Output Type	NPN
Diagnosis	point diagnosis
Sync. Factor	0V(potential group 24VDC)
Output Current	0.5A/ch
Load Type	Resistive, Inductive, Lamp

Module LED					
EtherCat		ProfiNet		EtherNet/IP	
PWR	GN: module power normally				
	RD: module power reverse				
I/O	GN: channel signal normally				
	RD: port power supply short circuit				
LINK	GN: Link normally				
	YE flash: link & data transmission normally				
	Light off: module unlinked				
RUN	GN: OP status	SF	RD: module fault	MS	GN: module work normally
	GN flash (slowly): SAFEOP status		RD: Internal error		GN flash: unconfigured / unlinked
	GN flash (quickly): Pre-OP status	BF	RD flash: device Name / IP error	NS	RD flash: device Name / IP error
	light off: Init status		RD flash: device Name / IP error		GN: Network normally
ERR	RD flash: communication error			NS	GN flash: Network unlinked
	Light off: module work normally				RD flash: communication error

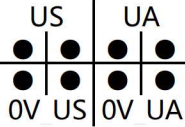
Pin Sequence (Power)	Pin Sequence (I/O)																																																																				
	<table border="1"> <tr> <td>V+</td><td>V-</td><td>V+</td><td>V-</td><td>V+</td><td>V-</td><td>V+</td><td>V-</td><td>V+</td><td>V-</td><td>V+</td><td>V-</td><td>V+</td><td>V-</td><td>V+</td><td>V-</td><td>V+</td><td>V-</td> </tr> <tr> <td>I0</td><td>I1</td><td>I2</td><td>I3</td><td>I4</td><td>I5</td><td>I6</td><td>I7</td><td>I8</td><td>I9</td><td>I10</td><td>I11</td><td>I12</td><td>I13</td><td>I14</td><td>I15</td><td></td><td></td> </tr> </table> <table border="1"> <tr> <td>O0</td><td>O1</td><td>O2</td><td>O3</td><td>O4</td><td>O5</td><td>O6</td><td>O7</td><td>O8</td><td>O9</td><td>O10</td><td>O11</td><td>O12</td><td>O13</td><td>O14</td><td>O15</td> </tr> <tr> <td>V+</td><td>V+</td><td>V+</td><td>V+</td><td>V+</td><td>V+</td><td>V+</td><td>V+</td><td>V+</td><td>V+</td><td>V+</td><td>V+</td><td>V+</td><td>V+</td><td>V+</td><td>V+</td> </tr> </table>	V+	V-	V+	V-	V+	V-	V+	V-	V+	V-	V+	V-	V+	V-	V+	V-	V+	V-	I0	I1	I2	I3	I4	I5	I6	I7	I8	I9	I10	I11	I12	I13	I14	I15			O0	O1	O2	O3	O4	O5	O6	O7	O8	O9	O10	O11	O12	O13	O14	O15	V+	V+	V+	V+	V+	V+	V+	V+	V+	V+	V+	V+	V+	V+	V+	V+
V+	V-	V+	V-	V+	V-	V+	V-	V+	V-	V+	V-	V+	V-	V+	V-	V+	V-																																																				
I0	I1	I2	I3	I4	I5	I6	I7	I8	I9	I10	I11	I12	I13	I14	I15																																																						
O0	O1	O2	O3	O4	O5	O6	O7	O8	O9	O10	O11	O12	O13	O14	O15																																																						
V+	V+	V+	V+	V+	V+	V+	V+	V+	V+	V+	V+	V+	V+	V+	V+																																																						



IO-LINK Master

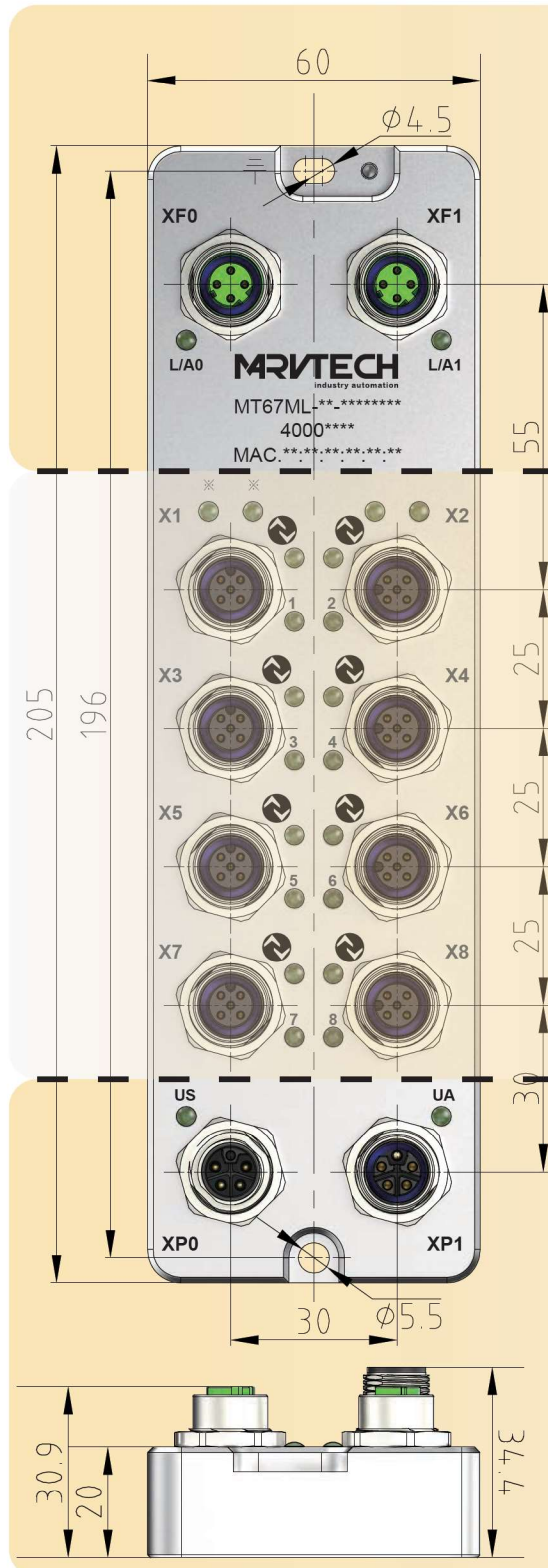

Pin Definition (Data Port)

M12 D-code Female	Connection Type	2 x M12 D-code; 4-pin Female	XF0 , XF1  1. TX+ 2. RX+ 3. TX- 4. RX-
	Physical layer	Ethernet	
	Transfer rate	10/100 Mbps, Full Duplex	
	Min. Cycle Time	1 ms	
	Port fixed torque	M12 : 0.5Nm	

Basic parameters

Housing material	Aluminum alloy
Housing color	Metallic Silver
Protection level	IP67
Dimensions (W x H x D)	205mm x 60mm x 34.4mm
Weight	515g
Operating temperature	-25°C...70°C
Storage temperature	-40°C...85°C
Operating humidity	5%...95%
Storage humidity	5%...95%
Operating Atmospheric pressure	80KPa...106KPa
Storage Atmospheric pressure	80KPa...106KPa
Tightening torque(I/O)	M12:0.5Nm
Application Environment	According EN-61131
Vibration Test	According IEC60068-2
Impact Test	According IEC60068-27
Free Drop Test	According IEC60068-32
EMC	According IEC61000-4-2,-3,-4
Certification	CE,RoHS
Mounting Hole size	Φ4.5mm x 1, Φ5.5mm x 1

Pin Definition (Power Port)

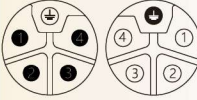
Power Supply Port	Connection Type	M12, 5pol, L-code, Female&Male	XP0 XP1  Male Female 1. +24V_Us 2. GND_Ua 3. GND_Us 4. +24V_Ua 5. FE
	System voltage Us	18...30 VDC (type.24VDC)	
	Auxiliary voltage Ua	18...30 VDC (type.24VDC)	
	Current sum Is	12A	
M12 L-code Female& Male	Current sum Ia	12A	
	No-load current Ic	≤150mA	
	Reverse power protection	Yes	
	Tightening torque (Power)	M12:0.5Nm	

Order Information				
Interface	Model	Order No.	Description	I/O Connection Type
	MT67ML-EC-IOLM8A	40000230	IO-LINK Master Module 8 Class A port IP67	M12, 5pin Female, A-code
	MT67ML-PN-IOLM8A	40000167		
	MT67ML-EI-IOLM8A	40000254		

IO-Link Data			
IO-LINK Interfaces(Master)	Max. 8 Ports	Ports voltage L+	type.24VDC (via US)
Connection (IO-LINK)	M12, 5Pin, A-code, Female	Ports current L+	2A (via US)
IO-link Ver.	V1.1.2	Class A	8 Ports, X1...X8
Data transmission rate	COM1: 4.8KBps	Communication distance	≤20m
	COM2: 38.4KBps		
	COM3: 230.4KBps		

Digital Input/Output			
Input Ports	8-way, adaptive	Output Ports	8-way, adaptive
Input Ports ID	X1...X8	Output Ports ID	X1...X8
Digital Input TYPE	PNP	Digital Output TYPE	PNP
Signal "0" voltage	-0.3...5VDC	Output current	2A each Port (via UA)
Signal "1" voltage	12...30VDC	Port protection	Output short circuit & overload protection
Input current	type.5mA (via US)		

Module LED					
EtherCat		ProfiNet		EtherNet/IP	
PWR	GN: module power normally				
	RD: module power reverse				
I/O	GN: channel signal normally				
	RD: port power supply short circuit				
LINK	GN: Link normally				
	YE flash: link & data transmission normally				
RUN	Light off: module unlinked				
	GN: OP status	SF	RD: module fault	MS	GN: module work normally
	GN flash (slowly): SAFEOP status		RD flash: Internal error		GN flash: unconfigured / unlinked
	GN flash (quickly): Pre-OP status	BF	RD flash: device Name / IP error	NS	RD flash: device Name / IP error
light off: Init status	RD flash: communication error		GN: Network normally		
ERR	RD flash: communication error				GN flash: Network unlinked
	Light off: module work normally				RD flash: communication error
IO-LINK	GN: Port operation (operational) status				
	GN flash (fast): Port connecting				
	GN flash (slow): Port standing by				
	Light off: Port closed				

Pin Definition (I/O port)																				
	Pins	Address																		
I/O port	M12(X1~X8) 	<table border="1"> <tr><th>Byte</th><th>0</th></tr> <tr><td>Bit0</td><td>X1P2</td></tr> <tr><td>Bit1</td><td>X2P2</td></tr> <tr><td>Bit2</td><td>X3P2</td></tr> <tr><td>Bit3</td><td>X4P2</td></tr> <tr><td>Bit4</td><td>X5P2</td></tr> <tr><td>Bit5</td><td>X6P2</td></tr> <tr><td>Bit6</td><td>X7P2</td></tr> <tr><td>Bit7</td><td>X8P2</td></tr> </table>	Byte	0	Bit0	X1P2	Bit1	X2P2	Bit2	X3P2	Bit3	X4P2	Bit4	X5P2	Bit5	X6P2	Bit6	X7P2	Bit7	X8P2
Byte	0																			
Bit0	X1P2																			
Bit1	X2P2																			
Bit2	X3P2																			
Bit3	X4P2																			
Bit4	X5P2																			
Bit5	X6P2																			
Bit6	X7P2																			
Bit7	X8P2																			
M12 A-code Female	Class A 1. V+ 2. In/Output 3. 0 V 4. C/Q																			

Order Information

Interface	Model	Order No.	Description	I/O Connection Type
	MT67ML-EC-IOLM4A4B	40000253	IO-LINK Master Module 4 Class A port 4 Class B port IP67	M12, 5pin Female, A-code
	MT67ML-PN-IOLM4A4B	40000122		
	MT67ML-EI-IOLM4A4B	40000255		

IO-Link Data

IO-LINK Interfaces(Master)	Max. 8 Ports	Ports voltage L+	type.24VDC (via US)
Connection (IO-LINK)	M12, 5Pin, A-code, Female	Ports current L+	2A (via US)
IO-link Ver.	V1.1.2	ClassB auxiliary voltage	type.24VDC (via UA)
Data transmission rate	COM1 : 4.8KBps	ClassB auxiliary current	2A (via UA)
	COM2: 38.4KBps	Class A	4 Ports, X1...X4
	COM3: 230.4KBps	Class B	4 Ports, X5...X8
Communication distance	≤20m		

Digital Input/Output

Input Ports	4-way, adaptive	Output Ports	4-way, adaptive
Input Ports ID	X1...X4	Output Ports ID	X1...X4
Digital Input TYPE	PNP	Digital Output TYPE	PNP
Signal "0" voltage	-0.3...5VDC	Output current	2A each Port (via UA)
Signal "1" voltage	12...30VDC	Port protection	Output short circuit & overload protection
Input current	type.5mA (via US)		

Module LED

	EtherCat	ProfiNet	EtherNet/IP
PWR		GN: module power normally	
		RD: module power reverse	
I/O		GN: channel signal normally	
		RD: port power supply short circuit	
LINK		GN: Link normally	
		YE flash: link & data transmission normally	
RUN	GN: OP status	SF	RD: module fault
	GN flash (slowly): SAFEOP status		MS
	GN flash (quickly): Pre-OP status	BF	
	light off: Init status		RD flash: device Name / IP error
ERR	RD flash: communication error		GN flash: Network unlinked
	Light off: module work normally		RD flash: communication error
IO-LINK			GN: Port operation (operational) status
			GN flash (fast): Port connecting
			GN flash (slow): Port standing by
			Light off: Port closed

Pin Definition (I/O port)

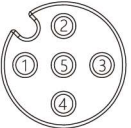
	Pins	Address
I/O port	M12(X1~X8) 	
M12 A-code Female	Class A	
	Class B	
	1. V+	1. V+
	2. In/Output	2. P24V
	3. 0 V	3. 0 V
	4. C/Q	4. C/Q
		5. N24V
		Byte 0
		Bit0 X1P2
		Bit1 X2P2
		Bit2 X3P2
		Bit3 X4P2

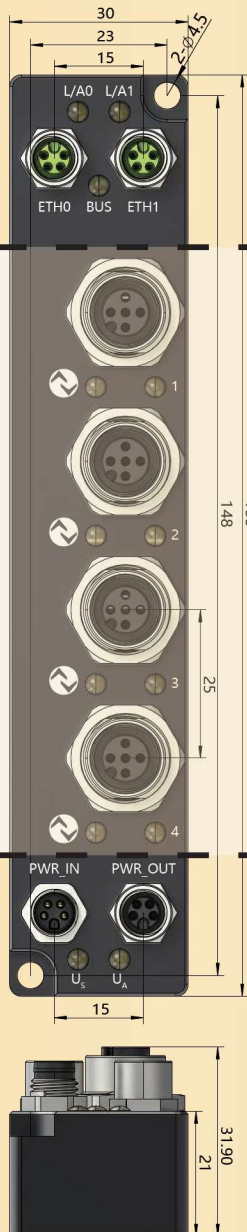

Pin Definition (Data Port)



M8 A-code Female	Connection Type	2 × M8 D-code; 4-pin Female	ETH0 , ETH1 1. TX+ 2. RX+ 3. TX- 4. RX-
	Physical layer	Ethernet	
	Transfer rate	10/100 Mbps, full duplex	
	Characteristic	Compliant with the protocol	
	Alarm function	Diagnostic&process alarms	
	Min. Cycle Time	250 μs	
	Port fixed torque	M8:0.5Nm	

Basic parameters

Housing material	Aluminum alloy
Housing color	Anodized black
Protection level	IP67 , epoxy full potting
Dimensions (W x H x D)	155mm × 30mm × 31.9mm
Weight	208g
Operating temperature	-25°C...70°C
Storage temperature	-40°C...85°C
Operating humidity	5%...95%
Storage humidity	5%...95%
Operating Atmospheric pressure	80KPa...106KPa
Storage Atmospheric pressure	80KPa...106KPa
Tightening torque(I/O)	M12:0.5Nm
Application Environment	According EN-61131
Vibration Test	According IEC60068-2
Impact Test	According IEC60068-27
Free Drop Test	According IEC60068-32
EMC	According IEC61000-4-2,-3,-4
Certification	CE, RoHS
Mounting Hole size	Φ4.5mm × 2

Pin Definition (Power Port)

Power Supply Port	Connection Type	M8, 4pol, A-code, Female&Male	PWR_IN PWR_OUT Male Female 1. +24V_Us 2. +24V_Ua 3. GND_Us 4. GND_Ua
	System voltage U _s	18...30 VDC (type.24VDC)	
	Auxiliary voltage U _a	18...30 VDC (type.24VDC)	
	Current sum I _s	4A	
	Current sum I _a	4A	
M8 A-code Female& Male	No-load current I _c	≤150mA	
	Reverse power protection	Yes	
	Tightening torque (Power)	M8:0.5Nm	

Order Information				
Interface	Model	Order No.	Description	I/O Connection Type
	MT67MC-EC-IOLM4A	40000259	IO-LINK Master Module 4 Class A port IP67	M12, 5pin Female, A-code
	MT67MC-PN-IOLM4A	40000168		
	MT67MC-EI-IOLM4A	40000262		

IO-Link Data			
IO-LINK Interfaces(Master)	Max. 8 Ports	Ports voltage L+	type.24VDC (via US)
Connection (IO-LINK)	M12, 5Pin, A-code, Female	Ports current L+	2A (via US)
IO-link Ver.	V1.1.2	Class A	4 Ports, X1...X4
Data transmission rate	COM1: 4.8KBps	Communication distance	≤20m
	COM2: 38.4KBps		
	COM3: 230.4KBps		

Digital Input/Output			
Input Ports	4-way, adaptive	Output Ports	4-way, adaptive
Input Ports ID	X1...X4	Output Ports ID	X1...X4
Digital Input TYPE	PNP	Digital Output TYPE	PNP
Signal "0" voltage	-0.3...5VDC	Output current	2A each Port (via UA)
Signal "1" voltage	12...30VDC	Port protection	Output short circuit & overload protection
Input current	type.5mA (via US)		

Module LED					
EtherCat		ProfiNet		EtherNet/IP	
PWR	GN: module power normally				
	RD: module power reverse				
L/A0 L/A1	GN: channel signal normally				
	GN flash: extended communication normally				
I/O	GN: channel signal normally				
	RD: port power supply short circuit				
BUS	GN: OP status	BUS	Off: module work normally	BUS	GN: module work normally
	GN flash (slowly): SAFEOP status		RD: module work abnormally		GN flash: unconfigured / unlinked
	GN flash (quickly): Pre-OP status		RD flash: device Name / IP error		RD flash: device Name / IP error
	light off: Init status				
	RD&GN flash: communication error				
IO-LINK	GN: Port operation (operational) status				
	GN flash (fast): Port connecting				
	GN flash (slow): Port standing by				
	Light off: Port closed				

Pin Definition (I/O port)												
	Pins	Address										
I/O port	M12(X1~X4) 											
M12 A-code Female	Class A 1. V+ 2. In/Output 3. 0 V 4. C/Q	<table border="1"> <tr> <td>Byte</td> <td>0</td> </tr> <tr> <td>Bit0</td> <td>X1P2</td> </tr> <tr> <td>Bit1</td> <td>X2P2</td> </tr> <tr> <td>Bit2</td> <td>X3P2</td> </tr> <tr> <td>Bit3</td> <td>X4P2</td> </tr> </table>	Byte	0	Bit0	X1P2	Bit1	X2P2	Bit2	X3P2	Bit3	X4P2
Byte	0											
Bit0	X1P2											
Bit1	X2P2											
Bit2	X3P2											
Bit3	X4P2											



IO-LINK Device

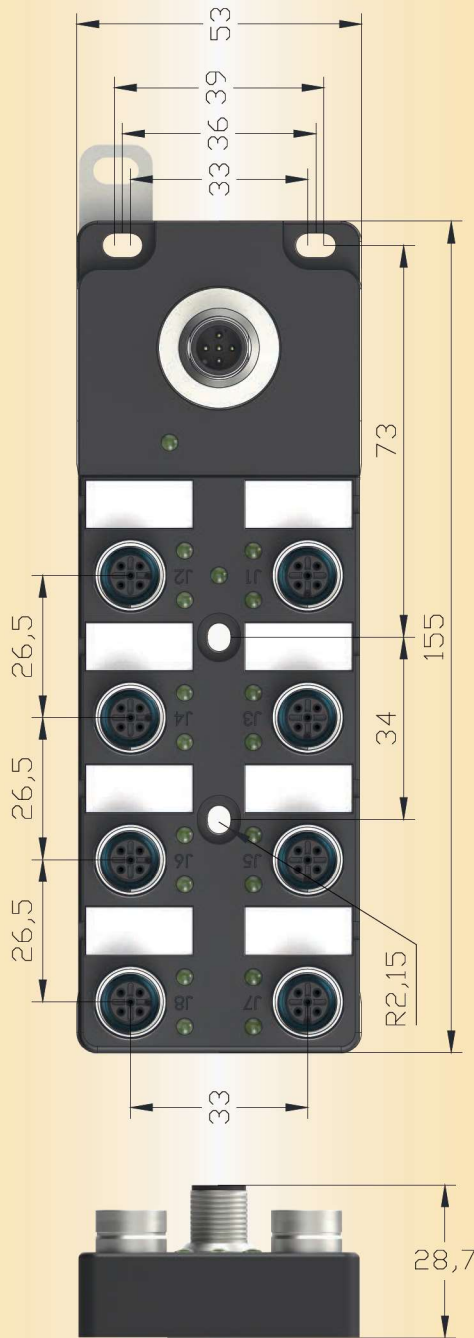

Pin Definition (Data Port)

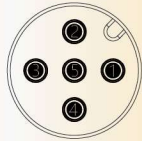
IO-LINK Port	IO-Link M12 MALE		<ol style="list-style-type: none"> 1. V+ 2. P24V 3. 0 V 4. C/Q 5. N24V

Basic parameters

Housing material	PA6 + GF
Housing color	Black
Protection level	IP67
Dimensions (W x H x D)	155mm x 53mm x 28,7mm
Weight	217g
Operating temperature	-25°C...70°C
Storage temperature	-40°C...85°C
Operating humidity	5%...95%
Storage humidity	5%...95%
Operating Atmospheric pressure	80KPa...106KPa
Storage Atmospheric pressure	80KPa...106KPa
Tightening torque(I/O)	M12:0.5Nm
Application Environment	According EN-61131
Vibration Test	According IEC60068-2
Impact Test	According IEC60068-27
Free Drop Test	According IEC60068-32
EMC	According IEC61000-4-2,-3,-4
Certification	CE, RoHS
Mounting Hole size	Φ4.3mm x 4

Order Information					
IO-Link	TYPE	Model	Order No.	Description	I/OConnection Type
Class A	PNP	IOLD-PA-DI16P	40000143	IO-LINK Slave Module 8 × Port IP67	M12, 5pin Female, A-code
	NPN	IOLD-PA-DI16N	40000145		

IO-Link Data	
IO-LINK Interfaces	1 × Device
IO-Link Process data	2 Byte
Min. Cycle time	3 ms

Digital Input	
Digital inputs	Max. 16
Input voltage	18...30V DC
Switching current, sensor	200 mA
Switching current, actuator	-
Total Current UI	< 1.6A
Total Current UO	-

Module Indicator	
IO-LINK RUN	GN: Network unlinked
	GN flash: Network normally
PWR	RD: communication error
	GN: module power normally
I/O	Light off: module no power
	GN: channel signal normally
	RD: port error

Pin Definition (I/O port)																																				
I/O port	Pins		Address																																	
	M12(X1~X8)		Byte 1	Byte 0																																
M12 A-code Female	<p>PNP</p> <p>Input</p> <ol style="list-style-type: none"> 24 VDC+ Input 0 V Input FE 	 <p>NPN</p> <p>Input</p> <ol style="list-style-type: none"> 24 VDC+ Input 0 V Input FE 	<table border="1"> <tr><td>Bit0</td><td>J1P4</td></tr> <tr><td>Bit1</td><td>J1P2</td></tr> <tr><td>Bit2</td><td>J2P4</td></tr> <tr><td>Bit3</td><td>J2P2</td></tr> <tr><td>Bit4</td><td>J3P4</td></tr> <tr><td>Bit5</td><td>J3P2</td></tr> <tr><td>Bit6</td><td>J4P4</td></tr> <tr><td>Bit7</td><td>J4P2</td></tr> </table>	Bit0	J1P4	Bit1	J1P2	Bit2	J2P4	Bit3	J2P2	Bit4	J3P4	Bit5	J3P2	Bit6	J4P4	Bit7	J4P2	<table border="1"> <tr><td>Bit8</td><td>J5P4</td></tr> <tr><td>Bit9</td><td>J5P2</td></tr> <tr><td>Bit10</td><td>J6P4</td></tr> <tr><td>Bit11</td><td>J6P2</td></tr> <tr><td>Bit12</td><td>J7P4</td></tr> <tr><td>Bit13</td><td>J7P2</td></tr> <tr><td>Bit14</td><td>J8P4</td></tr> <tr><td>Bit15</td><td>J8P2</td></tr> </table>	Bit8	J5P4	Bit9	J5P2	Bit10	J6P4	Bit11	J6P2	Bit12	J7P4	Bit13	J7P2	Bit14	J8P4	Bit15	J8P2
	Bit0	J1P4																																		
Bit1	J1P2																																			
Bit2	J2P4																																			
Bit3	J2P2																																			
Bit4	J3P4																																			
Bit5	J3P2																																			
Bit6	J4P4																																			
Bit7	J4P2																																			
Bit8	J5P4																																			
Bit9	J5P2																																			
Bit10	J6P4																																			
Bit11	J6P2																																			
Bit12	J7P4																																			
Bit13	J7P2																																			
Bit14	J8P4																																			
Bit15	J8P2																																			

Order Information					
IO-Link	Type	Model	Order No.	Description	I/OConnection Type
Class A	PNP	IOLD-PA-DO16P	40000144	IO-LINK Slave Module 8 × Port IP67	M12, 5pin Female, A-code
	NPN	IOLD-PA-DO16N	40000146		

IO-Link Data	
IO-LINK Interfaces	1 × Device
IO-Link Process data	2 Byte
Min. Cycle time	3 ms

Digital Input/Output	
Digital inputs/outputs	16 outputs
Input voltage	18...30V DC
Switching current, sensor	-
Switching current, actuator	500 mA
Total Current UI	-
Total Current UO	< 2.5A

Module Indicator	
IO-LINK RUN	GN: Network unlinked
	GN flash: Network normally
	RD: communication error
PWR	GN: module power normally
	YW: auxiliary power not connected
I/O	GN: channel signal normally
	RD: port error

Pin Definition (I/O port)																																				
I/O port	Pins		Address																																	
	M12(X1~X8)		Byte 1	Byte 0																																
M12 A-code Female		PNP Output 1. N/C 2. Output 3. 0 V 4. Output 5. FE	NPN Output 1. 24VDC+ 2. Output 3. N/C 4. Output 5. FE	<table border="1"> <tr><td>Bit0</td><td>J1P4</td><td>Bit8</td><td>J5P4</td></tr> <tr><td>Bit1</td><td>J1P2</td><td>Bit9</td><td>J5P2</td></tr> <tr><td>Bit2</td><td>J2P4</td><td>Bit10</td><td>J6P4</td></tr> <tr><td>Bit3</td><td>J2P2</td><td>Bit11</td><td>J6P2</td></tr> <tr><td>Bit4</td><td>J3P4</td><td>Bit12</td><td>J7P4</td></tr> <tr><td>Bit5</td><td>J3P2</td><td>Bit13</td><td>J7P2</td></tr> <tr><td>Bit6</td><td>J4P4</td><td>Bit14</td><td>J8P4</td></tr> <tr><td>Bit7</td><td>J4P2</td><td>Bit15</td><td>J8P2</td></tr> </table>	Bit0	J1P4	Bit8	J5P4	Bit1	J1P2	Bit9	J5P2	Bit2	J2P4	Bit10	J6P4	Bit3	J2P2	Bit11	J6P2	Bit4	J3P4	Bit12	J7P4	Bit5	J3P2	Bit13	J7P2	Bit6	J4P4	Bit14	J8P4	Bit7	J4P2	Bit15	J8P2
		Bit0	J1P4	Bit8	J5P4																															
Bit1	J1P2	Bit9	J5P2																																	
Bit2	J2P4	Bit10	J6P4																																	
Bit3	J2P2	Bit11	J6P2																																	
Bit4	J3P4	Bit12	J7P4																																	
Bit5	J3P2	Bit13	J7P2																																	
Bit6	J4P4	Bit14	J8P4																																	
Bit7	J4P2	Bit15	J8P2																																	

Order Information					
IO-Link	Type	Model	Order No.	Description	I/OConnection Type
Class A	PNP	IOLD-PA-DIO16P	40000140	IO-LINK Slave Module 8 × Port IP67	M12, 5pin Female, A-code
	NPN	IOLD-PA-DIO16N	40000147		

IO-Link Data	
IO-Link Data	1 × Device
IO-Link Process data	2 Byte
Min. Cycle time	3 ms

Digital Input/Output	
Digital inputs/outputs	Max. 16
Input voltage	18...30V DC
Switching current, sensor	200 mA
Switching current, actuator	500 mA
Total Current UI	< 1.6A
Total Current UO	< 2.5A

Module Indicator	
IO-LINK RUN	GN: Network unlinked
	GN flash: Network normally
PWR	RD: communication error
	GN: module power normally
I/O	YW: auxiliary power not connected
	GN: channel signal normally
	RD: port error

Pin Definition (I/O port)					
I/O port	Pins		Address		
	M12(X1~X8)		Byte	1	Byte
M12 A-code Female		PNP Input/Output 1. 24 VDC+ 2. Input/Output 3. 0 V 4. Input/Output 5. FE	NPN Input/Output 1. 24 VDC+ 2. Input/Output 3. 0 V 4. Input/Output 5. FE	Bit0 J1P4 Bit1 J1P2 Bit2 J2P4 Bit3 J2P2 Bit4 J3P4 Bit5 J3P2 Bit6 J4P4 Bit7 J4P2	Bit8 J5P4 Bit9 J5P2 Bit10 J6P4 Bit11 J6P2 Bit12 J7P4 Bit13 J7P2 Bit14 J8P4 Bit15 J8P2

Order Information					
IO-Link	Type	Model	Order No.	Description	I/OConnection Type
Class A	PNP	IOLD-PA-DI8PDO8P	40000139	IO-LINK Slave Module 8 × Port IP67	M12, 5pin Female, A-code
	NPN	IOLD-PA-DI8NDO8N	40000148		

IO-Link Data	
IO-Link Data	1 × Device
IO-Link Process data	1 Byte
Min. Cycle time	3 ms

Digital Input/Output	
Digital inputs/outputs	8 inputs/8 outputs
Input voltage	18...30V DC
Switching current, sensor	200 mA
Switching current, actuator	500 mA
Total Current UI	< 1.6A
Total Current UO	< 2.5A

Module Indicator	
IO-LINK RUN	GN: Network unlinked
	GN flash: Network normally
PWR	RD: communication error
	GN: module power normally
I/O	YW: auxiliary power not connected
	GN: channel signal normally
	RD: port error

Pin Definition (I/O port)								
I/O port	Pins				Address			
	M12(X1~X8)				Byte 1		Byte 0	
M12 A-code Female					Bit0	J1P4	Bit8	J5P4
	PNP Input Output		NPN Input Output		Bit1	J1P2	Bit9	J5P2
	1. 24 VDC+	1. N/C	1. 24 VDC+	1. 24VDC+	Bit2	J2P4	Bit10	J6P4
	2. Input	2. Output	2. Input	2. Output	Bit3	J2P2	Bit11	J6P2
	3. 0 V	3. 0 V	3. 0 V	3. N/C	Bit4	J3P4	Bit12	J7P4
	4. Input	4. Output	4. Input	4. Output	Bit5	J3P2	Bit13	J7P2
	5. FE	5. FE	5. FE	5. FE	Bit6	J4P4	Bit14	J8P4
					Bit7	J4P2	Bit15	J8P2

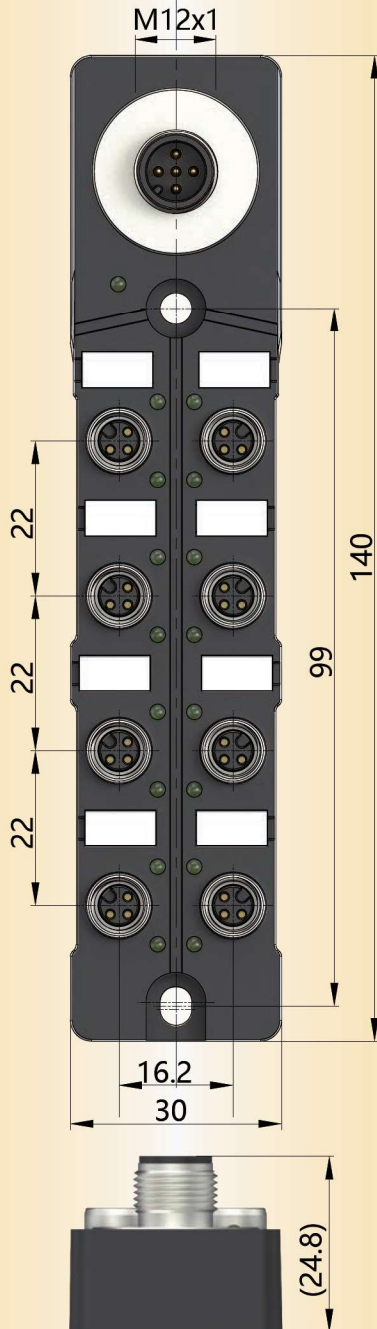

Data Port Pin Definition	
IO-LINK	<p>IO-Link M12 MALE</p> <p>1. V+ 2. P24V 3. 0 V 4. C/Q 5. N24V</p>
Port	
Pin Definition	

Basic parameters	
Housing material	PA6 + GF
Housing color	Black
Protection level	IP67, Epoxy full potting
Dimensions (W x H x D)	140mm x 30mm x 24.8mm
Weight	180g
Operating temperature	-25°C...70°C
Storage temperature	-40°C...85°C
Operating humidity	5%...95%
Storage humidity	5%...95%
Operating Atmospheric pressure	80KPa...106KPa
Storage Atmospheric pressure	80KPa...106KPa
Tightening torque(I/O)	M12:0.5Nm
Application Environment	According to EN-61131
Vibration Test	According to IEC60068-2
Impact Test	According to IEC60068-27
Free Drop Test	According to IEC60068-32
EMC	According to IEC61000-4-2,-3,-4
Certification	CE,RoHS
Mounting Hole size	Φ4.3mm x 2

Order Information					
IO-Link	Type	Model	Order No.	Description	I/O Connection Type
Class A	PNP	IOLD-PA-DI8P-M8	40000171	IO-LINK Slave Module 8 × Port IP67	M18, 3pin Female, A-code
	NPN	IOLD-PA-DI8N-M8	40000172		

IO-Link Data	
IO-Link Data	1 × Device
IO-Link Process data	2 Byte
Min. Cycle time	3 ms

Digital Input/Output	
Digital inputs/outputs	8 inputs
Input voltage	18...30V DC
Switching current, sensor	200 mA
Switching current, actuator	-
Total Current UI	< 1.6A
Total Current UO	-

Module Indicator	
IO-LINK RUN	GN: Network unlinked
	GN flash: Network normally
I/O	RD: communication error
	GN: channel signal normally RD: port error

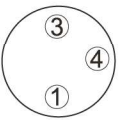
Pin Definition (I/O port)																				
	Pins	Address																		
I/O port	M8(X1~X8)																			
																				
M8 A-code Female	<p>PNP</p> <p>Input</p> <p>1. 24 VDC+</p> <p>4. Input</p> <p>3. 0 V</p>	<table border="1"> <thead> <tr> <th>Byte</th> <th>1</th> </tr> </thead> <tbody> <tr> <td>Bit0</td> <td>J1P4</td> </tr> <tr> <td>Bit1</td> <td>J2P4</td> </tr> <tr> <td>Bit2</td> <td>J3P4</td> </tr> <tr> <td>Bit3</td> <td>J4P4</td> </tr> <tr> <td>Bit4</td> <td>J5P4</td> </tr> <tr> <td>Bit5</td> <td>J6P4</td> </tr> <tr> <td>Bit6</td> <td>J7P4</td> </tr> <tr> <td>Bit7</td> <td>J8P4</td> </tr> </tbody> </table>	Byte	1	Bit0	J1P4	Bit1	J2P4	Bit2	J3P4	Bit3	J4P4	Bit4	J5P4	Bit5	J6P4	Bit6	J7P4	Bit7	J8P4
Byte	1																			
Bit0	J1P4																			
Bit1	J2P4																			
Bit2	J3P4																			
Bit3	J4P4																			
Bit4	J5P4																			
Bit5	J6P4																			
Bit6	J7P4																			
Bit7	J8P4																			
	<p>NPN</p> <p>Input</p> <p>1. 24 VDC+</p> <p>4. Input</p> <p>3. 0 V</p>																			

Order Information					
IO-Link	Type	Model	Order No.	Description	I/O Connection Type
Class A	PNP	IOLD-PA-DO8P-M8	40000177	IO-LINK Slave Module 8 × Port IP67	M18, 3pin Female, A-code
	NPN	IOLD-PA-DO8N-M8	40000178		

IO-Link Data	
IO-Link Data	1 × Device
IO-Link Process data	2 Byte
Min. Cycle time	3 ms

Digital Input/Output	
Digital input/output	8 outputs
Input voltage	18...30V DC
Switching current, sensor	-
Switching current, actuator	500 mA
Total Current UI	-
Total Current UO	< 2.5A

Module Indicator	
IO-LINK RUN	GN: Network unlinked
	GN flash: Network normally
I/O	RD: communication error
	GN: channel signal normally
	RD: port error

Pin Definition (I/O port)																				
	Pins	Address																		
I/O port	M8(X1~X8)																			
M8 A-code Female	<p>PNP Output</p> <p>1. N/C</p> <p>4. Output</p> <p>3. 0 V</p>	<p>NPN Output</p> <p>1. 24VDC+</p> <p>4. Output</p> <p>3. N/C</p>																		
		<table border="1"> <thead> <tr> <th>Byte</th> <th>1</th> </tr> </thead> <tbody> <tr> <td>Bit0</td> <td>J1P4</td> </tr> <tr> <td>Bit1</td> <td>J2P4</td> </tr> <tr> <td>Bit2</td> <td>J3P4</td> </tr> <tr> <td>Bit3</td> <td>J4P4</td> </tr> <tr> <td>Bit4</td> <td>J5P4</td> </tr> <tr> <td>Bit5</td> <td>J6P4</td> </tr> <tr> <td>Bit6</td> <td>J7P4</td> </tr> <tr> <td>Bit7</td> <td>J8P4</td> </tr> </tbody> </table>	Byte	1	Bit0	J1P4	Bit1	J2P4	Bit2	J3P4	Bit3	J4P4	Bit4	J5P4	Bit5	J6P4	Bit6	J7P4	Bit7	J8P4
Byte	1																			
Bit0	J1P4																			
Bit1	J2P4																			
Bit2	J3P4																			
Bit3	J4P4																			
Bit4	J5P4																			
Bit5	J6P4																			
Bit6	J7P4																			
Bit7	J8P4																			

Order Information					
IO-Link	Type	Model	Order No.	Description	I/OConnection Type
Class A	PNP	IOLD-PA-DIO8P-M8	40000231	IO-LINK Slave Module 8 × Port IP67	M18, 3pin Female, A-code
	NPN	IOLD-PA-DIO8N-M8	40000232		

IO-Link Data	
IO-Link Data	1 × Device
IO-Link Process data	2 Byte
Min. Cycle time	3 ms

Digital Input/Output	
Digital inputs/outputs	Max. 8
Input voltage	18...30V DC
Switching current, sensor	200 mA
Switching current, actuator	500 mA
Total Current UI	< 1.6A
Total Current UO	< 2.5A

Module Indicator	
IO-LINK RUN	GN: Network unlinked
	GN flash: Network normally
I/O	RD: communication error
	GN: channel signal normally
	RD: port error

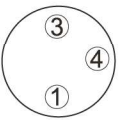
Pin Definition (I/O port)																				
	Pins	Address																		
I/O port	M8(X1~X8)																			
																				
M8 A-code Female	<p>PNP Input/Output 1. 24 VDC+ 4. Input/Output 3. 0 V</p>	<table border="1"> <thead> <tr> <th>Byte</th> <th>1</th> </tr> </thead> <tbody> <tr> <td>Bit0</td> <td>J1P4</td> </tr> <tr> <td>Bit1</td> <td>J2P4</td> </tr> <tr> <td>Bit2</td> <td>J3P4</td> </tr> <tr> <td>Bit3</td> <td>J4P4</td> </tr> <tr> <td>Bit4</td> <td>J5P4</td> </tr> <tr> <td>Bit5</td> <td>J6P4</td> </tr> <tr> <td>Bit6</td> <td>J7P4</td> </tr> <tr> <td>Bit7</td> <td>J8P4</td> </tr> </tbody> </table>	Byte	1	Bit0	J1P4	Bit1	J2P4	Bit2	J3P4	Bit3	J4P4	Bit4	J5P4	Bit5	J6P4	Bit6	J7P4	Bit7	J8P4
Byte	1																			
Bit0	J1P4																			
Bit1	J2P4																			
Bit2	J3P4																			
Bit3	J4P4																			
Bit4	J5P4																			
Bit5	J6P4																			
Bit6	J7P4																			
Bit7	J8P4																			
	<p>NPN Input/Output 1. 24 VDC+ 4. Input/Output 3. 0 V</p>																			

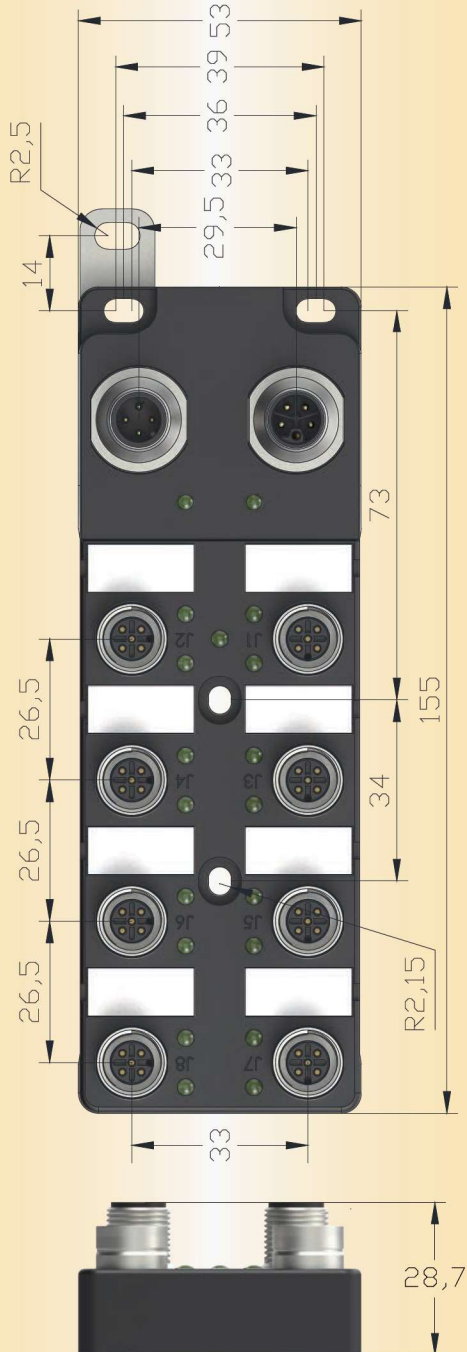

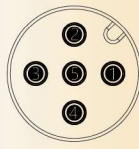
Data Port Pin Definition	
IO-LINK	IO-Link M12 MALE
Port	
Pin Definition	1. V+ 2. P24V 3. 0 V 4. C/Q 5. N24V

Basic parameters	
Housing material	PA6 + GF
Housing color	Black
Protection level	IP67, Epoxy full potting
Dimensions (W x H x D)	155mm x 53mm x 28.7mm
Weight	227g
Operating temperature	-25°C...70°C
Storage temperature	-40°C...85°C
Operating humidity	5%...95%
Storage humidity	5%...95%
Operating Atmospheric pressure	80KPa...106KPa
Storage Atmospheric pressure	80KPa...106KPa
Tightening torque(I/O)	M12:0.5Nm
Application Environment	According to EN-61131
Vibration Test	According to IEC60068-2
Impact Test	According to IEC60068-27
Free Drop Test	According to IEC60068-32
EMC	According to IEC61000-4-2,-3,-4
Certification	CE,RoHS
Mounting Hole size	Φ4.3mm x 4

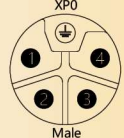
Auxiliary Power Port Pin Definition		
Auxiliary Power Port	Power connection	M12, 5pins, L-code, Female/Male
	System Power Voltage	18...30 VDC (type.24VDC)
	Auxiliary Power Voltage	18...30 VDC (type.24VDC)
	Total Current	12A
	Total Current	12A
	Static Current	≤150mA
	Anti-error Insertion	Available
L-code Female	Tightening torque(Power)	M12:0.5Nm
Pin Definition		
		 <p>Male</p> 1. +24V_Us 2. GND_Ua 3. GND_Us 4. +24V_Ua 5. FE

Order Information					
IO-Link	Type	Model	Order No.	Description	I/OConnection Type
Class A	PNP	IOLD-PAV-DO16P-2A	40000185	IO-LINK Slave Module 8 × Port IP67	M12, 5pin Female, A-code

IO-Link Data	
IO-Link Data	1 × Device
IO-Link Process data	2 Byte
Min. Cycle time	3 ms

Digital Input/Output	
Digital inputs/outputs	16 outputs
Input voltage	18...30V DC
Switching current, sensor	-
Switching current, actuator	2A
Total Current UI	-
Total Current UO	< 12A

Module Indicator	
IO-LINK RUN	GN: Network unlinked
	GN flash: Network normally
PWR	RD: communication error
	GN: module power normally
I/O	Off: Module power not connected
	GN: channel signal normally
AUX	RD: port error
	GN: auxiliary power normally
	Red: auxiliary power reversely connected
	Off: auxiliary power not connected

Pin Definition (I/O port)					
I/O port	Pins		Address		
	M12(X1~X8)		Byte 1	Byte 0	
M12 A-code Female	 <p>PNP Output 1. N/C 2. Output 3. 0 V 4. Output 5. FE</p>	Bit0	J1P4	Bit8	J5P4
		Bit1	J1P2	Bit9	J5P2
		Bit2	J2P4	Bit10	J6P4
		Bit3	J2P2	Bit11	J6P2
		Bit4	J3P4	Bit12	J7P4
		Bit5	J3P2	Bit13	J7P2
		Bit6	J4P4	Bit14	J8P4
		Bit7	J4P2	Bit15	J8P2

Order Information					
IO-Link	Type	Model	Order No.	Description	I/OConnection Type
Class A	PNP	IOLD-PAV-DIO16P-2A	40000166	IO-LINK Slave Module 8 × Port IP67	M12, 5pin Female, A-code

IO-Link Data	
IO-Link Data	1 × Device
IO-Link Process data	2 Byte
Max. Cycle time	3 ms

Digital Input/Output	
Digital inputs/outputs	Max. 16
Input voltage	18...30V DC
Switching current, sensor	200 mA
Switching current, actuator	2A
Total Current UI	< 1.6A
Total Current UO	< 12A

Module Indicator	
IO-LINK RUN	GN: Network unlinked
	GN flash: Network normally
	RD: communication error
PWR	GN: module power normally
	Off: Module power not connected
I/O	GN: channel signal normally
	RD: port error
AUX	GN: auxiliary power normally
	Red: auxiliary power reversely connected
	Off: auxiliary power not connected

Pin Definition (I/O port)																																							
I/O port	Pins		Address																																				
	M12 A-code Female	M12(X1~X8)	 <p>PNP Input/Output</p> <ol style="list-style-type: none"> 24 VDC+ Input/Output 0 V Input/Output FE 	<table border="1"> <thead> <tr> <th>Byte</th> <th>1</th> <th>Byte</th> <th>0</th> </tr> </thead> <tbody> <tr> <td>Bit0</td> <td>J1P4</td> <td>Bit8</td> <td>J5P4</td> </tr> <tr> <td>Bit1</td> <td>J1P2</td> <td>Bit9</td> <td>J5P2</td> </tr> <tr> <td>Bit2</td> <td>J2P4</td> <td>Bit10</td> <td>J6P4</td> </tr> <tr> <td>Bit3</td> <td>J2P2</td> <td>Bit11</td> <td>J6P2</td> </tr> <tr> <td>Bit4</td> <td>J3P4</td> <td>Bit12</td> <td>J7P4</td> </tr> <tr> <td>Bit5</td> <td>J3P2</td> <td>Bit13</td> <td>J7P2</td> </tr> <tr> <td>Bit6</td> <td>J4P4</td> <td>Bit14</td> <td>J8P4</td> </tr> <tr> <td>Bit7</td> <td>J4P2</td> <td>Bit15</td> <td>J8P2</td> </tr> </tbody> </table>	Byte	1	Byte	0	Bit0	J1P4	Bit8	J5P4	Bit1	J1P2	Bit9	J5P2	Bit2	J2P4	Bit10	J6P4	Bit3	J2P2	Bit11	J6P2	Bit4	J3P4	Bit12	J7P4	Bit5	J3P2	Bit13	J7P2	Bit6	J4P4	Bit14	J8P4	Bit7	J4P2	Bit15
Byte	1	Byte	0																																				
Bit0	J1P4	Bit8	J5P4																																				
Bit1	J1P2	Bit9	J5P2																																				
Bit2	J2P4	Bit10	J6P4																																				
Bit3	J2P2	Bit11	J6P2																																				
Bit4	J3P4	Bit12	J7P4																																				
Bit5	J3P2	Bit13	J7P2																																				
Bit6	J4P4	Bit14	J8P4																																				
Bit7	J4P2	Bit15	J8P2																																				

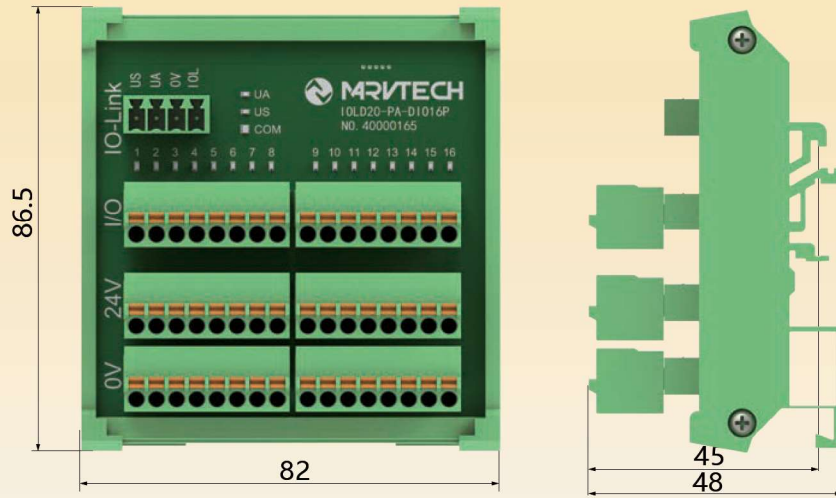

Data Port Pin Definition	
	IO-Link
IO-LINK	1. V+
Port	2. P24V
Pin Definition	3. 0 V
	4. C/Q

Basic parameters	
Housing material	PA66
Housing color	Green
Protection level	IP20
Dimensions (W x H x D)	86.5mm x 82mm x 48mm
Weight	137g
Operating temperature	-25°C...70°C
Storage temperature	-40°C...85°C
Operating humidity	5%...95%
Storage humidity	5%...95%
Operating Atmospheric pressure	80KPa...106KPa
Storage Atmospheric pressure	80KPa...106KPa
Tightening torque(I/O)	M12:0.5Nm
Certification	CE,RoHS
Installation specifications	Rail type

Order Information					
IO-Link	Type	Model	Order No.	Description	I/OConnection Type
Class A	PNP	IOLD20-PA-DI16P	40000192	IO-LINK Slave Module 16 × Port IP20	Terminal Connection, 16×1 Spring Terminal, max.1.5mm ²
	NPN	IOLD20-PA-DI16N	40000193		

IO-Link Data	
IO-Link Data	1 × Device
IO-Link Process data	2 Byte
Min. Cycle time	3 ms

Digital Input/Output	
Digital inputs/outputs	16 inputs
Input voltage	18...30V DC
Switching current, sensor	200 mA
Switching current, actuator	-
Total Current UI	< 1.6A
Total Current UO	-

Module Indicator	
COM	GN: Network unlinked
	GN flash: Network normally
	RD: communication error
I/O	GN: channel signal normally
	Off: no signal
US	GN: module power normally
	Off: module power not connected
UA	GN: auxiliary power normally
	Off: auxiliary power not connected

Pin Definition (I/O port)																																																																																																																																							
Pins																Address																																																																																																																							
<table border="1" style="width: 100%; text-align: center;"> <tr> <td colspan="16">16 DI</td> </tr> <tr> <td colspan="8">Byte 0</td> <td colspan="8">Byte 1</td> </tr> <tr> <td>I/O</td> <td>1</td><td>2</td><td>3</td><td>4</td><td>5</td><td>6</td><td>7</td><td>8</td> <td>9</td><td>10</td><td>11</td><td>12</td><td>13</td><td>14</td><td>15</td><td>16</td> </tr> <tr> <td>24V</td> <td colspan="8">24 V</td> <td colspan="8"></td> </tr> <tr> <td>0V</td> <td colspan="8">0 V</td> <td colspan="8"></td> </tr> </table>																16 DI																Byte 0								Byte 1								I/O	1	2	3	4	5	6	7	8	9	10	11	12	13	14	15	16	24V	24 V																0V	0 V																<table border="1" style="width: 100%;"> <tr> <td>Byte</td> <td>0</td> <td>Byte</td> <td>1</td> </tr> <tr> <td>Bit0</td> <td>1</td> <td>Bit0</td> <td>9</td> </tr> <tr> <td>Bit1</td> <td>2</td> <td>Bit1</td> <td>10</td> </tr> <tr> <td>Bit2</td> <td>3</td> <td>Bit2</td> <td>11</td> </tr> <tr> <td>Bit3</td> <td>4</td> <td>Bit3</td> <td>12</td> </tr> <tr> <td>Bit4</td> <td>5</td> <td>Bit4</td> <td>13</td> </tr> <tr> <td>Bit5</td> <td>6</td> <td>Bit5</td> <td>14</td> </tr> <tr> <td>Bit6</td> <td>7</td> <td>Bit6</td> <td>15</td> </tr> <tr> <td>Bit7</td> <td>8</td> <td>Bit7</td> <td>16</td> </tr> </table>	Byte	0	Byte	1	Bit0	1	Bit0	9	Bit1	2	Bit1	10	Bit2	3	Bit2	11	Bit3	4	Bit3	12	Bit4	5	Bit4	13	Bit5	6	Bit5	14	Bit6	7	Bit6	15	Bit7	8	Bit7	16
																16 DI																																																																																																																							
																Byte 0								Byte 1																																																																																																															
																I/O	1	2	3	4	5	6	7	8	9	10	11	12	13	14	15	16																																																																																																							
24V	24 V																																																																																																																																						
0V	0 V																																																																																																																																						
Byte	0	Byte	1																																																																																																																																				
Bit0	1	Bit0	9																																																																																																																																				
Bit1	2	Bit1	10																																																																																																																																				
Bit2	3	Bit2	11																																																																																																																																				
Bit3	4	Bit3	12																																																																																																																																				
Bit4	5	Bit4	13																																																																																																																																				
Bit5	6	Bit5	14																																																																																																																																				
Bit6	7	Bit6	15																																																																																																																																				
Bit7	8	Bit7	16																																																																																																																																				

Order Information					
IO-Link	Type	Model	Order No.	Description	I/OConnection Type
Class A	PNP	IOLD20-PA-DO16P	40000200	IO-LINK Slave Module 16 × Port IP20	Terminal Connection, 16×1 Spring Terminal, max.1.5mm ²
	NPN	IOLD20-PA-DO16N	40000201		

IO-Link Data	
IO-Link Data	1 × Device
IO-Link Process data	2 Byte
Min. Cycle time	3 ms

Digital Input/Output	
Digital inputs/outputs	16 outputs
Input voltage	18...30V DC
Switching current, sensor	-
Switching current, actuator	500 mA
Total Current UI	-
Total Current UO	< 2.5A

Module Indicator	
COM	GN: Network unlinked
	GN flash: Network normally
	RD: communication error
I/O	GN: channel signal normally
	Off: no signal
US	GN: module power normally
	Off: module power not connected
UA	GN: auxiliary power normally
	Off: auxiliary power not connected

Pin Definition (I/O port)																																																																																																																								
Pins	Address																																																																																																																							
<table border="1"> <tr> <td colspan="16">16 DO</td> </tr> <tr> <td colspan="8">Byte 0</td> <td colspan="8">Byte 1</td> </tr> <tr> <td>I/O</td> <td>1</td><td>2</td><td>3</td><td>4</td><td>5</td><td>6</td><td>7</td><td>8</td> <td>9</td><td>10</td><td>11</td><td>12</td><td>13</td><td>14</td><td>15</td><td>16</td> </tr> <tr> <td>24V</td> <td colspan="8">24 V</td> <td colspan="8"></td> </tr> <tr> <td>0V</td> <td colspan="8">0 V</td> <td colspan="8"></td> </tr> </table>	16 DO																Byte 0								Byte 1								I/O	1	2	3	4	5	6	7	8	9	10	11	12	13	14	15	16	24V	24 V																0V	0 V																<table border="1"> <tr> <td>Byte</td> <td>0</td> <td>Byte</td> <td>1</td> </tr> <tr> <td>Bit0</td> <td>1</td> <td>Bit0</td> <td>9</td> </tr> <tr> <td>Bit1</td> <td>2</td> <td>Bit1</td> <td>10</td> </tr> <tr> <td>Bit2</td> <td>3</td> <td>Bit2</td> <td>11</td> </tr> <tr> <td>Bit3</td> <td>4</td> <td>Bit3</td> <td>12</td> </tr> <tr> <td>Bit4</td> <td>5</td> <td>Bit4</td> <td>13</td> </tr> <tr> <td>Bit5</td> <td>6</td> <td>Bit5</td> <td>14</td> </tr> <tr> <td>Bit6</td> <td>7</td> <td>Bit6</td> <td>15</td> </tr> <tr> <td>Bit7</td> <td>8</td> <td>Bit7</td> <td>16</td> </tr> </table>	Byte	0	Byte	1	Bit0	1	Bit0	9	Bit1	2	Bit1	10	Bit2	3	Bit2	11	Bit3	4	Bit3	12	Bit4	5	Bit4	13	Bit5	6	Bit5	14	Bit6	7	Bit6	15	Bit7	8	Bit7	16
16 DO																																																																																																																								
Byte 0								Byte 1																																																																																																																
I/O	1	2	3	4	5	6	7	8	9	10	11	12	13	14	15	16																																																																																																								
24V	24 V																																																																																																																							
0V	0 V																																																																																																																							
Byte	0	Byte	1																																																																																																																					
Bit0	1	Bit0	9																																																																																																																					
Bit1	2	Bit1	10																																																																																																																					
Bit2	3	Bit2	11																																																																																																																					
Bit3	4	Bit3	12																																																																																																																					
Bit4	5	Bit4	13																																																																																																																					
Bit5	6	Bit5	14																																																																																																																					
Bit6	7	Bit6	15																																																																																																																					
Bit7	8	Bit7	16																																																																																																																					

Order Information					
IO-Link	Type	Model	Order No.	Description	I/OConnection Type
Class A	PNP	IOLD20-PA-DIO16P	40000165	IO-LINK Slave Module 16 × Port IP20	Terminal Connection, 16×1 Spring Terminal, max.1.5mm ²
	NPN	IOLD20-PA-DIO16N	40000212		

IO-Link Data	
IO-Link Data	1 × Device
IO-Link Process data	2 Byte
Min. Cycle time	3 ms

Digital Input/Output	
Digital inputs/outputs	Max. 16
Input voltage	18...30V DC
Switching current, sensor	200 mA
Switching current, actuator	500 mA
Total Current UI	< 1.6A
Total Current UO	< 2.5A

Module Indicator	
COM	GN: Network unlinked
	GN flash: Network normally
	RD: communication error
I/O	GN: channel signal normally
	Off: no signal
US	GN: module power normally
	Off: module power not connected
UA	GN: auxiliary power normally
	Off: auxiliary power not connected

Pin Definition (I/O port)																																																																																																
Pins										Address																																																																																						
<table border="1"> <tr> <td colspan="16">16 DIO</td> </tr> <tr> <td colspan="8">Byte 0</td> <td colspan="8">Byte 1</td> </tr> <tr> <td>I/O</td> <td>1</td><td>2</td><td>3</td><td>4</td><td>5</td><td>6</td><td>7</td><td>8</td> <td>9</td><td>10</td><td>11</td><td>12</td><td>13</td><td>14</td><td>15</td><td>16</td> </tr> <tr> <td>24V</td> <td colspan="8">24 V</td> <td colspan="8"></td> </tr> <tr> <td>0V</td> <td colspan="8">0 V</td> <td colspan="8"></td> </tr> </table>										16 DIO																Byte 0								Byte 1								I/O	1	2	3	4	5	6	7	8	9	10	11	12	13	14	15	16	24V	24 V																0V	0 V																Byte	0	Byte	1
										16 DIO																																																																																						
										Byte 0								Byte 1																																																																														
										I/O	1	2	3	4	5	6	7	8	9	10	11	12	13	14	15	16																																																																						
24V	24 V																																																																																															
0V	0 V																																																																																															
Bit0	1	Bit0	9																																																																																													
Bit1	2	Bit1	10																																																																																													
Bit2	3	Bit2	11																																																																																													
Bit3	4	Bit3	12																																																																																													
Bit4	5	Bit4	13																																																																																													
Bit5	6	Bit5	14																																																																																													
Bit6	7	Bit6	15																																																																																													
Bit7	8	Bit7	16																																																																																													

Order Information					
IO-Link	Type	Model	Order No.	Order No.	I/OConnection Type
Class A	PNP	IOLD20-PA-DI8PDO8P	40000208	IO-LINK Slave Module 16 × Port IP20	Terminal Connection, 16×1 Spring Terminal, max.1.5mm ²
	NPN	IOLD20-PA-DI8NDO8N	40000209		

IO-Link Data	
IO-Link Data	1 × Device
IO-Link Process data	1 Byte
Max. Cycle time	3 ms

Digital Input/Output	
Digital inputs/outputs	8 inputs/8 outputs
Input voltage	18...30V DC
Switching current, sensor	200 mA
Switching current, actuator	500 mA
Total Current UI	< 1.6A
Total Current UO	< 2.5A

Module Indicator	
COM	GN: Network unlinked
	GN flash: Network normally
	RD: communication error
I/O	GN: channel signal normally
	Off: no signal
US	GN: module power normally
	Off: module power not connected
UA	GN: auxiliary power normally
	Off: auxiliary power not connected

Pin Definition (I/O port)																
Pins									Address							
	8Di								8DO							
	Byte 0								Byte 0							
I/O	1	2	3	4	5	6	7	8	9	10	11	12	13	14	15	16
24V									24 V							
0V									0 V							
									Byte	0	Byte	1				
									Bit0	1	Bit0	9				
									Bit1	2	Bit1	10				
									Bit2	3	Bit2	11				
									Bit3	4	Bit3	12				
									Bit4	5	Bit4	13				
									Bit5	6	Bit5	14				
									Bit6	7	Bit6	15				
									Bit7	8	Bit7	16				



MT20E Series Module

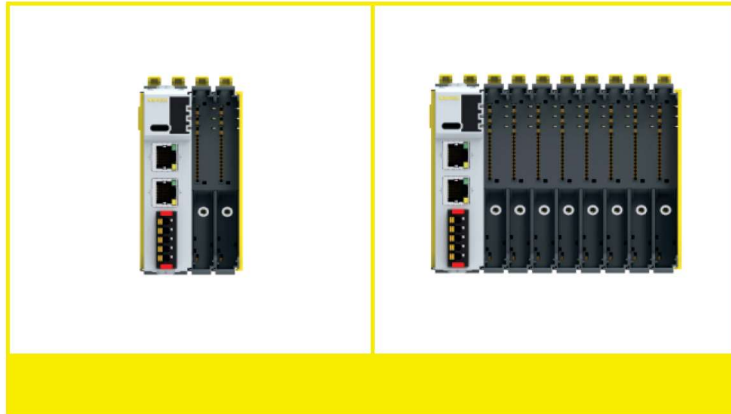

Profinet Coupler Modules

Features:

- 2 RJ45 interfaces, 100Mbit/s
- Expandable with 8 different E-series modules
- Compact size, saving more installation space
- Slot-type installation provides stable structure and faster response speed
- Supports hot replacement of expansion modules of the same model. No configuration is required when replacing equipment.

Commercial Data

Order No.	Model	Specification
40001000	MT20E-PN-B02	MT20E Coupler Modules, Profinet, 2 slots, DC24V
40001001	MT20E-PN-B04	MT20E Coupler Modules, Profinet, 4 slots, DC24V
40001002	MT20E-PN-B06	MT20E Coupler Modules, Profinet, 6 slots, DC24V
40001003	MT20E-PN-B08	MT20E Coupler Modules, Profinet, 8 slots, DC24V

Basic Parameters

Model	MT20E-PN-B02	MT20E-PN-B04	MT20E-PN-B06	MT20E-PN-B08
Number of Slots	2	4	6	8
Protection Level	IP20			
Coupler Size	104 × 61 × 24 mm			
Installation Width	48 mm	72 mm	96 mm	120 mm
Weight				
Operating Temperature	-25°C...70°C			
Operating Humidity	5%...95%			
Operating Atmospheric Pressure	80KPa...106KPa			

Technical Data

Physical Layer	Ethernet
Transfer Speed	10/100 Mbps, full duplex
Protocol	Profinet
Minimum Cycle Time	1ms
Communication Interface	2 × RJ45
Diagnostic Upload	Yes
System Power Supply	18...30 VDC (type.24VDC)
Total Current	≤6A
Static Working Current	≤150mA
Short Circuit/Reverse Conn. Protection	Yes
Firmware Upgrade	Yes
Hot Swap	Yes
Isolation	Optocoupler isolation

LED

PWR	Green: Normal power supply; Red: Undervoltage/overvoltage
BF	Off: Normal; Flashing red: Configuration/network abnormality
SF	Off: Normal; Red light: System failure
MOD	Green: Normal; Red: Expansion module configuration is inconsistent/Extension module is abnormal

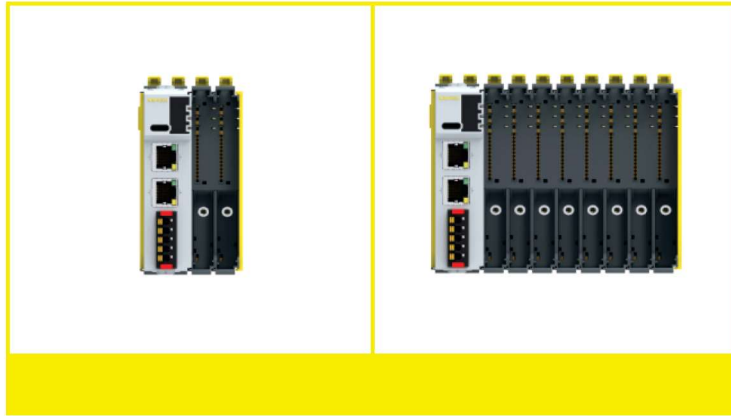

EtherCAT Coupler Modules

Features:

- 2 RJ45 interfaces, 100Mbit/s
- Expandable with 8 different E-series modules
- Compact size, saving more installation space
- Slot-type installation provides stable structure and faster response speed
- Supports hot replacement of expansion modules of the same model.
No configuration is required when replacing equipment.

Commercial Data

Order No.	Model	Specification
40001004	MT20E-EC-B02	MT20E Coupler Modules, EtherCAT, 2 slots, DC24V
40001005	MT20E-EC-B04	MT20E Coupler Modules, EtherCAT, 4 slots, DC24V
40001006	MT20E-EC-B06	MT20E Coupler Modules, EtherCAT, 6 slots, DC24V
40001007	MT20E-EC-B08	MT20E Coupler Modules, EtherCAT, 8 slots, DC24V

Basic Parameters

Model	MT20E-EC-B02	MT20E-EC-B04	MT20E-EC-B06	MT20E-EC-B08
Number of Slots	2	4	6	8
Protection Level	IP20			
Coupler Size	104 × 61 × 24 mm			
Installation Width	48 mm	72 mm	96 mm	120 mm
Weight				
Operating Temperature	-25°C...70°C			
Operating Humidity	5%...95%			
Operating Atmospheric Pressure	80KPa...106KPa			

Technical Data

Physical Layer	Ethernet
Transfer Speed	10/100 Mbps, full duplex
Protocol	EtherCAT
Minimum Cycle Time	1ms
Communication Interface	2 × RJ45
Diagnostic Upload	Yes
System Power Supply	18...30 VDC (type.24VDC)
Total Current	≤6A
Static Working Current	≤150mA
Short Circuit/Reverse Conn. Protection	Yes
Firmware Upgrade	Yes
Hot Swap	Yes
Isolation	Optocoupler isolation

LED

PWR	Green: Normal power supply; Red: Undervoltage/overvoltage
RUN	Green: The module is normal; Flashing green slowly: SAFEOP; Flashing green quickly: Pre-OP.
ERR	Off: Normal; Flashing red: Communication abnormality
MOD	Green: Normal; Red: Expansion module configuration is inconsistent/Extension module is abnormal

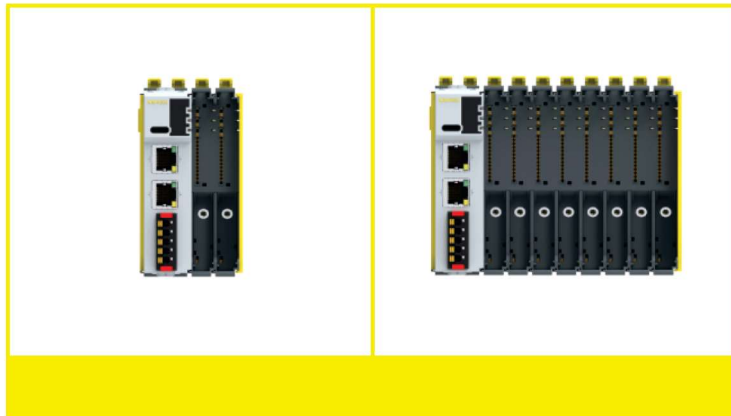

Ethernet/IP Coupler Modules

Features:

- 2 RJ45 interfaces, 100Mbit/s
- Expandable with 8 different E-series modules
- Compact size, saving more installation space
- Slot-type installation provides stable structure and faster response speed
- Supports hot replacement of expansion modules of the same model. No configuration is required when replacing equipment.

Commercial Data

Order No.	Model	Specification
40001008	MT20E-EI-B02	MT20E Coupler Modules, Ethernet/IP, 2 slots, DC24V
40001009	MT20E-EI-B04	MT20E Coupler Modules, Ethernet/IP, 4 slots, DC24V
40001010	MT20E-EI-B06	MT20E Coupler Modules, Ethernet/IP, 6 slots, DC24V
40001011	MT20E-EI-B08	MT20E Coupler Modules, Ethernet/IP, 8 slots, DC24V

Basic Parameters

Model	MT20E-EI-B02	MT20E-EI-B04	MT20E-EI-B06	MT20E-EI-B08
Number of Slots	2	4	6	8
Protection Level	IP20			
Coupler Size	104 × 61 × 24 mm			
Installation Width	48 mm	72 mm	96 mm	120 mm
Weight				
Operating Temperature	-25°C...70°C			
Operating Humidity	5%...95%			
Operating Atmospheric Pressure	80KPa...106KPa			

Technical Data

Physical Layer	Ethernet
Transfer Speed	10/100 Mbps, full duplex
Protocol	Ethernet/IP
Minimum Cycle Time	1ms
Communication Interface	2 × RJ45
Diagnostic Upload	Yes
System Power Supply	18...30 VDC (type.24VDC)
Total Current	≤6A
Static Working Current	≤150mA
Short Circuit/Reverse Conn. Protection	Yes
Firmware Upgrade	Yes
Hot Swap	Yes
Isolation	Optocoupler isolation

LED

PWR	Green: Normal power supply; Red: Undervoltage/overvoltage
MS	Green: Normal; Flashing green: The module is not configured; Red: Module fault
NS	Green: The network is normal; Flashing green: Communication is not established; Flashing red: Communication is interrupted.
MOD	Green: Normal; Red: Expansion module configuration is inconsistent/Extension module is abnormal

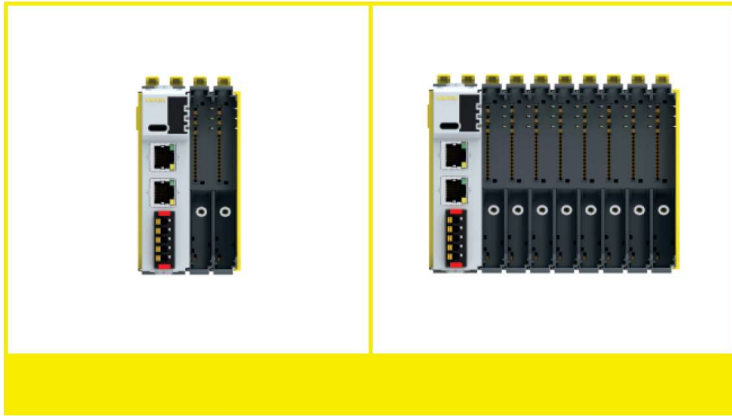

CC-Link IE Field Basic Coupler Modules

Features:

- 2 RJ45 interfaces, 100Mbit/s
- Expandable with 8 different E-series modules
- Compact size, saving more installation space
- Slot-type installation provides stable structure and faster response speed
- Supports hot replacement of expansion modules of the same model. No configuration is required when replacing equipment.

Commercial Data

Order No.	Model	Specification
40001012	MT20E-CB-B02	MT20E Coupler Modules, CC-Link IE Field Basic, 2 slots, DC24V
40001013	MT20E-CB-B04	MT20E Coupler Modules, CC-Link IE Field Basic, 4 slots, DC24V
40001014	MT20E-CB-B06	MT20E Coupler Modules, CC-Link IE Field Basic, 6 slots, DC24V
40001015	MT20E-CB-B08	MT20E Coupler Modules, CC-Link IE Field Basic, 8 slots, DC24V

Basic Parameters

Model	MT20E-CB-B02	MT20E-CB-B04	MT20E-CB-B06	MT20E-CB-B08
Number of Slots	2	4	6	8
Protection Level	IP20			
Coupler Size	104 × 61 × 24 mm			
Installation Width	48 mm	72 mm	96 mm	120 mm
Weight				
Operating Temperature	-25°C...70°C			
Operating Humidity	5%...95%			
Operating Atmospheric Pressure	80KPa...106KPa			

Technical Data

Physical Layer	Ethernet
Transfer Speed	10/100 Mbps, full duplex
Protocol	CC-Link IE Field Basic
Minimum Cycle Time	1ms
Communication Interface	2 × RJ45
Diagnostic Upload	Yes
System Power Supply	18...30 VDC (type.24VDC)
Total Current	≤6A
Static Working Current	≤150mA
Short Circuit/Reverse Conn. Protection	Yes
Firmware Upgrade	Yes
Hot Swap	Yes
Isolation	Optocoupler isolation

LED

PWR	Green: Normal power supply; Red: Undervoltage/overvoltage
RUN	Green: Normal; Green flashing slowly: The module is not configured; Green flashing quickly: Operation is normal, transmission stops
ERR	Off: Normal; Red: Communication abnormality
MOD	Green: Normal; Red: Expansion module configuration is inconsistent/Extension module is abnormal



Digital Input Modules

Features:

- Optocoupler isolation
- Compact size, saving more installation space
- Optional puncture-type and spring-type terminals to save wiring time
- Slot-type installation provides stable structure and faster response speed

Commercial Data

Order No.	Model	Specification
40001270	E-1600C	E series digital input module, 16 ports, PNP/NPN 24VDC, diagnostic function, Spring Terminal
40001283	E-1600C/IDC	E series digital input module, 16 ports, PNP/NPN 24VDC, diagnostic function, IDC Terminal

Basic Parameters

Model	E-1600C
Protection Level	IP20
Dimension	104 × 61 × 12mm
Weight	
Operating Temperature	-25°C...70°C
Operating Humidity	5%...95%
Operating Atmospheric Pressure	80KPa...106KPa

Technical Data

Input Type	Digital Input
Polarity	PNP/NPN
Input Channel	16
"0" Signal	PNP : -3~5V NPN : 15~30V
"1" Signal	PNP : 15~30V NPN : -3~5V
Software Filter Time	Yes
Diagnostic Upload	Yes
Hot Swap	Yes
Overvoltage/short circuit protection	Yes
Isolation	Optocoupler isolation
Static Working Current	≤100mA

LED

C0	Green: Channel A0...Channel A7 COM power supply is normal
C1	Green: Channel B0...Channel B7 COM power supply is normal
IO Signal LED	Green: input is valid



Digital Output Modules

Features:

- Optocoupler isolation
- Compact size, saving more installation space
- Optional puncture-type and spring-type terminals to save wiring time
- Slot-type installation provides stable structure and faster response speed

Commercial Data

Order No.	Model	Specification
40001271	E-0016P	E series Digital Output Modules, 16channel, PNP, 24VDC, diagnostic function, Spring Terminal
40001284	E-0016P/IDC	E series Digital Output Modules, 16channel, PNP, 24VDC, diagnostic function, IDC Terminal
40001272	E-0016N	E series Digital Output Modules, 16channel, NPN, 24VDC, diagnostic function, Spring Terminal
40001285	E-0016N/IDC	E series Digital Output Modules, 16channel, NPN, 24VDC, diagnostic function, IDC Terminal
40001273	E-0008R	E series Digital Output Modules, 8channel, Relay, 125V AC/30V DC, diagnostic function

Basic Parameters

Model	E-0016P	E-0016N	E-0008R
Protection Level	IP20		
Dimension	104 × 61 × 12 mm		
Weight			
Operating Temperature	-25°C...70°C		
Operating Humidity	5%...95%		
Operating Atmospheric Pressure	80KPa...106KPa		

Technical Data

Output Type	Transistor output		Relay output
Polarity	PNP	NPN	Relay output
Output Channel	16		8
Output Voltage	18...30V DC	0V DC	125V AC/30V DC
Current per Channel	0.5A/channel, 6A/module		2A/channel, 8A/module
Switch Lifetime	---		0.1 million times
Load Type	Resistive load, Inductive load, Lamp load		
Diagnostic Upload	Yes		
Hot Swap	Yes		
Overvoltage/short circuit protection	Yes		---
Isolation	Optocoupler isolation		
Static Working Current	≤100mA		

LED

C0	Green: power supply is normal
C1	Output overload
IO Signal LED	Green: Output is valid; Off: No output/output short circuit.



Digital Input/Output Modules

Features:

- Optocoupler isolation
- Compact size, saving more installation space
- Optional puncture-type and spring-type terminals to save wiring time
- Slot-type installation provides stable structure and faster response speed

Commercial Data

Order No.	Model	Specification
40001274	E-0808P	E series Digital Input/Output Module, 16channel, PNP, 24VDC, diagnostic function
40001275	E-0808N	E series Digital Input/Output Module, 16channel, NPN, 24VDC, diagnostic function

Basic Parameters

	E-0808P	E-0808N
Model	E-0808P	E-0808N
Protection Level	IP20	
Dimension	104 × 61 × 12mm	
Weight		
Operating Temperature	-25°C...70°C	
Operating Humidity	5%...95%	
Operating Atmospheric Pressure	80KPa...106KPa	

Technical Data

Signal Type	Digital Input/Output	
Polarity	PNP	NPN
Input/Output Channel	Input: 8 Output: 8	
Input "0" Signal (A0..A7)	-3~5V	15~30V
Input "1" Signal (A0..A7)	15~30V	-3~5V
Output Voltage (B0..B7)	18...30V DC	0V DC
Current per Channel (B0..B7)	0.5A/channel, 6A/module	
Load Type (B0..B7)	Resistive load, Inductive load, Lamp load	
Software Filter Time (A0..A7)	Yes	
Diagnostic Upload	Yes	
Hot Swap	Yes	
Overvoltage/short circuit protection	Yes	
Isolation	Optocoupler isolation	
Static Working Current	≤100mA	

LED

C0	Green: power supply is normal
C1	Output overload
IO Signal LED	Green: The signal is valid.; Off: The signal is invalid/output short circuit.

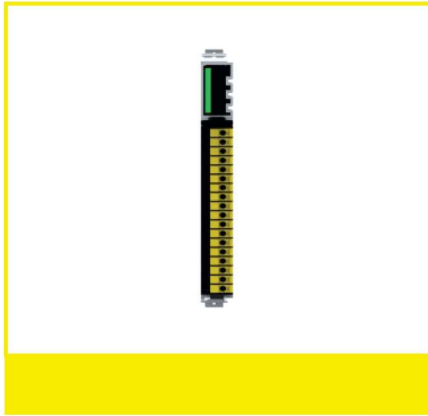

Analog Input Modules

Features:

- Optocoupler isolation
- Compact size, saving more installation space
- Optional puncture-type and spring-type terminals to save wiring time
- Slot-type installation provides stable structure and faster response speed

Commercial Data

Order No.	Model	Specification
40001276	E-AI4-I	E series Analog Input Modules, 4 channel, Current diagnostic function, 0~20mA, 4~20mA
40001277	E-AI4-V	E series Analog Input Modules, 4 channel, Voltage diagnostic function, 0~5V, 0~10V, 5~10V DC

Basic Parameters

Model	E-AI4-I	E-AI4-V
Protection Level	IP20	
Dimension	104 × 61 × 12mm	
Weight		
Operating Temperature	-25°C...70°C	
Operating Humidity	5%...95%	
Operating Atmospheric Pressure	80KPa...106KPa	

Technical Data

Input Type	Analog Input	
Polarity	Current	Voltage
Analog Channel	4	
Input Current Range	0~20mA; 4~20mA	0~5V; 0~10V; 5~10V DC
Input Error Range	< ±0.3%, full range	
Resolution	16 bit	
Measurement Display	0~65535	
Factory Setting	Channel default not used	
Ripple	< 1 %	
Diagnostic Upload	Yes	
Hot Swap	Yes	
Overvoltage/short circuit protection	Yes	
Isolation	Optocoupler isolation	
Static Working Current	≤100mA	

LED

C0	Green: power supply is normal
A0/A1/A2/A3	Green: The channel is normal.; Red: The channel reports an error.



Analog Output Modules

Features:

- Optocoupler isolation
- Compact size, saving more installation space
- Optional puncture-type and spring-type terminals to save wiring time
- Slot-type installation provides stable structure and faster response speed

Commercial Data

Order No.	Model	Specification
40001278	E-AO4-I	E series Analog Output Modules, 4 channel, Current diagnostic function, 0~20mA, 4~20mA
40001279	E-AO4-V	E series Analog Output Modules, 4 channel, Voltage diagnostic function, 0~5V, 0~10V, 5~10V DC

Basic Parameters

Model	E-AO4-I	E-AO4-V
Protection Level	IP20	
Dimension	104 × 61 × 12mm	
Weight		
Operating Temperature	-25°C...70°C	
Operating Humidity	5%...95%	
Operating Atmospheric Pressure	80KPa...106KPa	

Technical Data

Output Type	Analog Output	
Polarity	Current	Voltage
Analog Channel	4	
Output Current Range	0~20mA; 4~20mA	0~5V; 0~10V; 5~10V DC
Output Error Range	< ±0.3%, full range	
Resolution	16 bit	
Measurement Display	0~65535	
Factory Setting	Channel default not used	
Ripple	< 1 %	
Diagnostic Upload	Yes	
Hot Swap	Yes	
Overvoltage/short circuit protection	Yes	
Isolation	Optocoupler isolation	
Static Working Current	≤100mA	

LED

C0	Green: power supply is normal
A0/A1/A2/A3	Green: The channel is normal.; Red: The channel reports an error.



Temperature Measurement Modules

Features:

- Optocoupler isolation
- Compact size, saving more installation space
- Optional puncture-type and spring-type terminals to save wiring time
- Slot-type installation provides stable structure and faster response speed

Commercial Data

Order No.	Model	Specification
40001280	E-AI4-TC	E series Temperature Measurement, 4 channel, Thermocouple diagnostic function, J/K/E/N/R/S/B/T
40001281	E-AI4-PT	E series Temperature Measurement, 4 channel, Thermal Resistance diagnostic function, PT100/PT500/PT1000

Basic Parameters

Model	E-AI4-TC	E-AI4-PT
Protection Level	IP20	
Dimension	104 × 61 × 12mm	
Weight		
Operating Temperature	-25°C...70°C	
Operating Humidity	5%...95%	
Operating Atmospheric Pressure	80KPa...106KPa	

Technical Data

Input Type	Thermocouple	Thermal Resistance
Input Channel	4	
Input Type	J/K/E/N/R/S/B/T	PT100/PT500/PT1000
Wiring Type	Two-wire	Two-wire/Three-wire/Four-wire
Filter Time	0S-10S(Default: 0)	
Resolution	16 bit	
Range Error	J/E/N/R/S/B: < ±2°C K: < ±2°C T: -200~0°C < ±7% 0~400°C < ±2%	Two-wire: < ±0.3% Others: < ±0.2%
Function Setting	Disconnection detection (value cleared after disconnection) Measure up and down detection Upper and lower threshold settings	
Diagnostic Upload	Yes	
Factory Setting	Channel default not used	
Hot Swap	Yes	
Overvoltage/short circuit protection	Yes	
Isolation	Optocoupler isolation	
Static Working Current	≤100mA	

LED

C0	Green: power supply is normal
----	-------------------------------



MT20E IO-Link Master

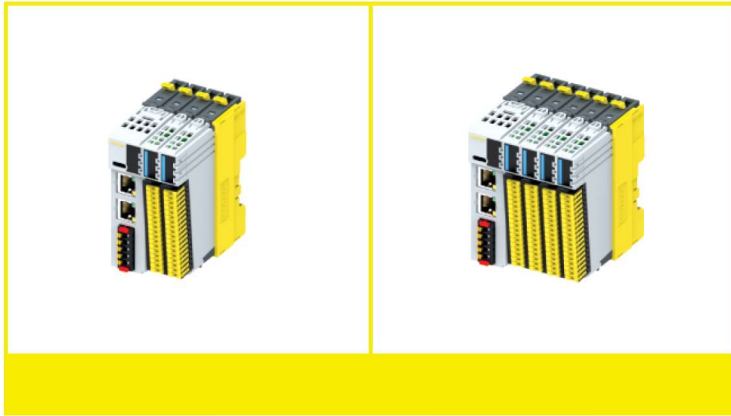

**Profinet
IO-Link Master**

Features:

- 2 RJ45 interfaces, 100Mbit/s
- expandable up to 16 IO-Link devices
- Compact size, saving more installation space
- expandable up to 1024 digital inputs or outputs
- standard IO-Link interface, adaptable to various IO-Link standard interface devices

Commercial Data

Order No.	Model	Specification
40001050	MT20E-PN-M08	MT20E IO-Link Master, Profinet, DC24V, default comes with 2 master station expansion modules, Spring Terminal
40001056	MT20E-PN-M08/IDC	MT20E IO-Link Master, Profinet, DC24V, default comes with 2 master station expansion modules, IDC Terminal
40001051	MT20E-PN-M16	MT20E IO-Link Master, Profinet, DC24V, default comes with 4 master station expansion modules, Spring Terminal
40001057	MT20E-PN-M16/IDC	MT20E IO-Link Master, Profinet, DC24V, default comes with 4 master station expansion modules, IDC Terminal

Basic Parameters

Model	MT20E-PN-M08	MT20E-PN-M16
Protection Level	IP20	
Dimension	104 × 61 × 48 mm	104 × 61 × 72 mm
Weight		
Operating Temperature	-25°C...70°C	
Operating Humidity	5%...95%	
Operating Atmospheric Pressure	80KPa...106KPa	

Technical Data

Network Physical Layer	Ethernet
Network Transfer Speed	10/100 Mbps, full duplex
Network Protocol	Profinet
Network Minimum Cycle Time	1ms
Communication Interface	2 × RJ45
IO-Link Channel	8
IO-Link Type	Class A
IO-Link Version	V1.1.2
IO-Link Transfer Speed	COM1: 4.8KBps; COM2: 38.4KBps; COM3: 230.4KBps
Distance between Mater and Slave	≤ 20 M
Diagnostic Upload	Yes
System Power Supply	18...30 VDC (type.24VDC)
Total Current	≤6A
Static Working Current	≤150mA
Short Circuit/Reverse Conn. Protection	Yes
Firmware Upgrade	Yes
Hot Swap	Yes
Isolation	Optocoupler isolation

LED

PWR	Green: Normal power supply; Red: Undervoltage/overvoltage
BF	Off: Normal; Flashing red: Configuration/network abnormality
SF	Off: Normal; Red light: System failure
MOD	Green: Normal; Red: Expansion module configuration is inconsistent/Extension module is abnormal

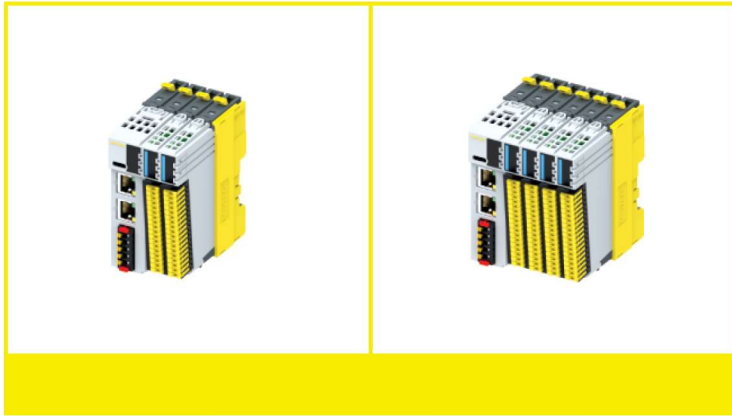

EtherCAT IO-Link Master

Features:

- 2 RJ45 interfaces, 100Mbit/s
- expandable up to 16 IO-Link devices
- Compact size, saving more installation space
- expandable up to 1024 digital inputs or outputs
- standard IO-Link interface, adaptable to various IO-Link standard interface devices

Commercial Data

Order No.	Model	Specification
40001052	MT20E-EC-M08	MT20E IO-Link Master, EtherCAT, DC24V, default comes with 2 master station expansion modules, Spring Terminal
40001058	MT20E-EC-M08/IDC	MT20E IO-Link Master, EtherCAT, DC24V, default comes with 2 master station expansion modules, IDC Terminal
40001053	MT20E-EC-M16	MT20E IO-Link Master, EtherCAT, DC24V, default comes with 4 master station expansion modules, Spring Terminal
40001059	MT20E-EC-M16/IDC	MT20E IO-Link Master, EtherCAT, DC24V, default comes with 4 master station expansion modules, IDC Terminal

Basic Parameters

Model	MT20E-EC-M08	MT20E-EC-M16
Protection Level	IP20	
Dimension	104 × 61 × 48 mm	104 × 61 × 72 mm
Weight		
Operating Temperature	-25°C...70°C	
Operating Humidity	5%...95%	
Operating Atmospheric Pressure	80KPa...106KPa	

Technical Data

Network Physical Layer	Ethernet	
Network Transfer Speed	10/100 Mbps, full duplex	
Network Protocol	EtherCAT	
Network Minimum Cycle Time	1ms	
Communication Interface	2 × RJ45	
IO-Link Channel	8	16
IO-Link Type	Class A	
IO-Link Version	V1.1.2	
IO-Link Transfer Speed	COM1: 4.8KBps; COM2: 38.4KBps; COM3: 230.4KBps	
Distance between Mater and Slave	≤ 20 M	
Diagnostic Upload	Yes	
System Power Supply	18...30 VDC (type.24VDC)	
Total Current	≤6A	
Static Working Current	≤150mA	
Short Circuit/Reverse Conn. Protection	Yes	
Firmware Upgrade	Yes	
Hot Swap	Yes	
Isolation	Optocoupler isolation	

LED

PWR	Green: Normal power supply; Red: Undervoltage/overvoltage
RUN	Green: The module is normal; Flashing green slowly: SAFEOP; Flashing green quickly: Pre-OP.
ERR	Off: Normal; Flashing red: Communication abnormality
MOD	Green: Normal; Red: Expansion module configuration is inconsistent/Extension module is abnormal

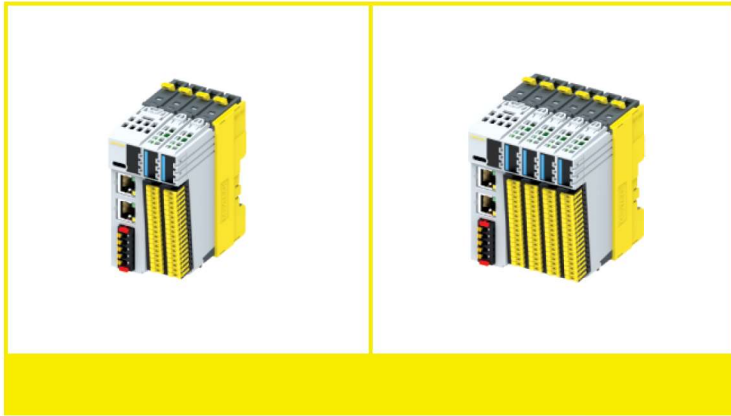

**Ethernet/IP
IO-Link Master**

Features:

- 2 RJ45 interfaces, 100Mbit/s
- expandable up to 16 IO-Link devices
- Compact size, saving more installation space
- expandable up to 1024 digital inputs or outputs
- standard IO-Link interface, adaptable to various IO-Link standard interface devices

Commercial Data

Order No.	Model	Specification
40001054	MT20E-EI-M08	MT20E IO-Link Master, Ethernet/IP, DC24V, default comes with 2 master station expansion modules, Spring Terminal
40001060	MT20E-EI-M08/IDC	MT20E IO-Link Master, Ethernet/IP, DC24V, default comes with 2 master station expansion modules, IDC Terminal
40001055	MT20E-EI-M16	MT20E IO-Link Master, Ethernet/IP, DC24V, default comes with 4 master station expansion modules, Spring Terminal
40001061	MT20E-EI-M16/IDC	MT20E IO-Link Master, Ethernet/IP, DC24V, default comes with 4 master station expansion modules, IDC Terminal

Basic Parameters

Model	MT20E-EI-M08	MT20E-EI-M16
Protection Level	IP20	
Dimension	104 × 61 × 48 mm	104 × 61 × 72 mm
Weight		
Operating Temperature	-25°C...70°C	
Operating Humidity	5%...95%	
Operating Atmospheric Pressure	80KPa...106KPa	

Technical Data

Network Physical Layer	Ethernet	
Network Transfer Speed	10/100 Mbps, full duplex	
Network Protocol	Ethernet/IP	
Network Minimum Cycle Time	1ms	
Communication Interface	2 × RJ45	
IO-Link Channel	8	16
IO-Link Type	Class A	
IO-Link Version	V1.1.2	
IO-Link Transfer Speed	COM1: 4.8KBps; COM2: 38.4KBps; COM3: 230.4KBps	
Distance between Mater and Slave	≤ 20 M	
Diagnostic Upload	Yes	
System Power Supply	18...30 VDC (type.24VDC)	
Total Current	≤6A	
Static Working Current	≤150mA	
Short Circuit/Reverse Conn. Protection	Yes	
Firmware Upgrade	Yes	
Hot Swap	Yes	
Isolation	Optocoupler isolation	

LED

PWR	Green: Normal power supply; Red: Undervoltage/overvoltage
MS	Green: Normal; Flashing green: The module is not configured; Red: Module fault
NS	Green: The network is normal; Flashing green: Communication is not established; Flashing red: Communication is interrupted.
MOD	Green: Normal; Red: Expansion module configuration is inconsistent/Extension module is abnormal



IO-Link Master Extension Modules

Features:

- Optocoupler isolation
- Compact size, saving more installation space
- Optional puncture-type and spring-type terminals to save wiring time
- Slot-type installation provides stable structure and faster response speed

Commercial Data

Order No.	Model	Specification
40001282	E-IOLM4	E series Master Extension Modules, 4 × Class A, Spring Terminal
40001295	E-IOLM4/IDC	E series Master Extension Modules, 4 × Class A, IDC Terminal

Basic Parameters

Model	E-IOLM4(only for E-series Master)
Protection Level	IP20
Dimension	104 × 61 × 12mm
Weight	
Operating Temperature	-25°C...70°C
Operating Humidity	5%...95%
Operating Atmospheric Pressure	80KPa...106KPa

Technical Data

IO-Link Channel	4
IO-Link Type	Class A
IO-Link Version	V1.1.2
IO-Link Transfer Speed	COM1: 4.8KBps; COM2: 38.4KBps; COM3: 230.4KBps
Distance between Mater and Slave	≤ 20 M
Input/Output Channel	4 channelPNP Input/Output configurable (set by C/Q)
Diagnostic Upload	Yes
Hot Swap	Yes
Overvoltage/short circuit protection	Yes
Isolation	Optocoupler isolation
Static Working Current	≤100mA

LED

L1+...L4+	Green: power supply is normal
K1...K4	Green: No communication connection with the IO-Link device/communication pin is set to IO Flashing green: The IO-Link device is connected normally



MT20E IO-Link Device

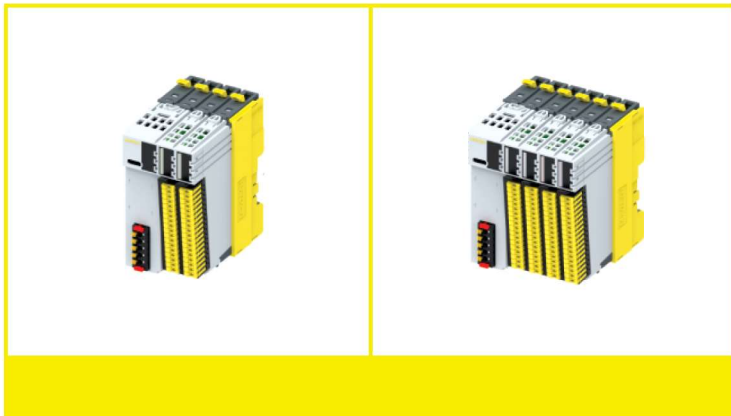

IO-Link Device Digital Input Modules

Features:

- Optocoupler isolation
- Compact size, saving more installation space
- Optional puncture-type and spring-type terminals to save wiring time
- Slot-type installation provides stable structure and faster response speed

Commercial Data

Order No.	Model	Specification
40001070	IOLD20E-PA-3200C	IO-Link Device,Digital Input Modules, 32channel, PNP/NPN, 24VDC, diagnostic function, Spring Terminal
40001088	IOLD20E-PA-3200C/IDC	IO-Link Device,Digital Input Modules, 32channel, PNP/NPN, 24VDC, diagnostic function, IDC Terminal
40001075	IOLD20E-PA-6400C	IO-Link Device,Digital Input Modules, 64 channel, PNP/NPN, 24VDC, diagnostic function, Spring Terminal
40001091	IOLD20E-PA-6400C/IDC	IO-Link Device,Digital Input Modules, 64 channel, PNP/NPN, 24VDC, diagnostic function, IDC Terminal

Basic Parameters

Model	IOLD20E-PA-3200C	IOLD20E-PA-6400C
Protection Level	IP20	
Dimension	104 × 61 × 48mm	104 × 61 × 72 mm
Weight		
Operating Temperature	-25°C...70°C	
Operating Humidity	5%...95%	
Operating Atmospheric Pressure	80KPa...106KPa	

Technical Data

Input Type	Digital Input	
Polarity	PNP/NPN	
Input Channel	32	64
"0" Signal	PNP : -3~5V NPN : 15~30V	
"1" Signal	PNP : 15~30V NPN : -3~5V	
Software Filter Time	Yes	
Diagnostic Upload	Yes	
Hot Swap	Yes	
Oversvoltage/short circuit protection	Yes	
Isolation	Optocoupler isolation	
Static Working Current	≤100mA	

LED

PWR	Green: power supply is normal
IOL	Green: There is no communication connection with the IO-Link device.; Flashing green: The IO-Link device is connected normally.
C0	Green: Channel A0...Channel A7 COM power supply is normal
C1	Green: Channel B0...Channel B7 COM power supply is normal
IO Signal LED	Green: input is valid

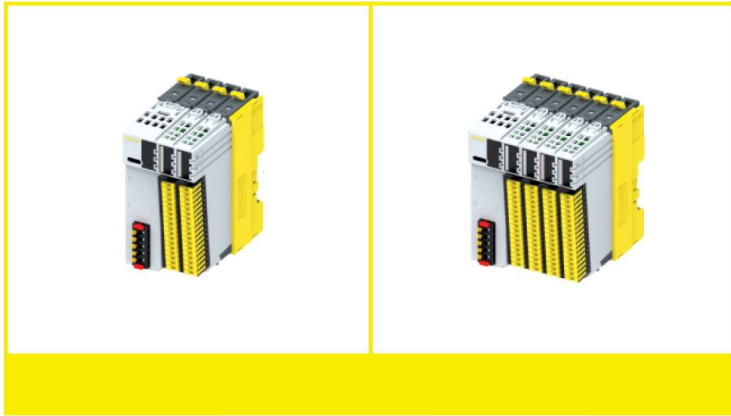

**IO-Link Device
Digital Output Modules**

Features:

- Optocoupler isolation
- Compact size, saving more installation space
- Optional puncture-type and spring-type terminals to save wiring time
- Slot-type installation provides stable structure and faster response speed

Commercial Data

Order No.	Model	Specification
40001071	IOLD20E-PA-0032P	IO-Link Device, Digital Output Modules, 32channel, PNP
40001072	IOLD20E-PA-0032N	IO-Link Device, Digital Output Modules, 32channel, NPN
40001076	IOLD20E-PA-0064P	IO-Link Device, Digital Output Modules, 64 channel, PNP
40001077	IOLD20E-PA-0064N	IO-Link Device, Digital Output Modules, 64 channel, NPN

Basic Parameters

Model	IOLD20E-PA-0032P	IOLD20E-PA-0032N	IOLD20E-PA-0064P	IOLD20E-PA-0064N
Protection Level	IP20			
Dimension	104 × 61 × 48 mm		104 × 61 × 72 mm	
Weight				
Operating Temperature	-25°C...70°C			
Operating Humidity	5%...95%			
Operating Atmospheric Pressure	80KPa...106KPa			

Output Type	Transistor output			
Polarity	PNP	NPN	PNP	NPN
Output Channel	32		64	
Output Voltage	18...30V DC	0V DC	18...30V DC	0V DC
Current per Channel	0.5A/channel, 6A/module			
Load Type	Resistive load, Inductive load, Lamp load			
Terminal Qty	2		4	
Diagnostic Upload	Yes			
Hot Swap	Yes			
Overvoltage/short circuit protection	Yes			
Isolation	Optocoupler isolation			
Static Working Current	≤200mA			

LED

PWR	Green: power supply is normal
IOL	Green: There is no communication connection with the IO-Link device.; Flashing green: The IO-Link device is connected normally.
C0	Green: power supply is normal
C1	Output overload
IO Signal LED	Green: Output is valid.; Off: No output/output short circuit.

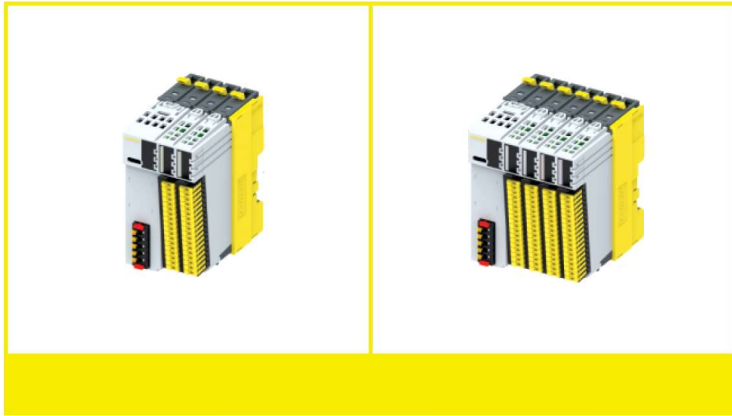

IO-Link Device Digital Output Modules

Features:

- Optocoupler isolation
- Compact size, saving more installation space
- Optional puncture-type and spring-type terminals to save wiring time
- Slot-type installation provides stable structure and faster response speed

Commercial Data

Order No.	Model	Specification
40001086	IOLD20E-PA-0016R	IO-Link Device, Digital Output Modules, 16channel, Relay
40001087	IOLD20E-PA-0032R	IO-Link Device, Digital Output Modules, 32channel, Relay

Basic Parameters

Model	IOLD20E-PA-0016R	IOLD20E-PA-0032R
Protection Level	IP20	
Dimension	104 × 61 × 48 mm	104 × 61 × 72 mm
Weight		
Operating Temperature	-25°C...70°C	
Operating Humidity	5%...95%	
Operating Atmospheric Pressure	80KPa...106KPa	

Output Type	Relay output	
Output Channel	16	32
Output Voltage	125V AC/30V DC	
Current per Channel	2A/channel, 8A/module	
Load Type	Resistive load, Inductive load, Lamp load	
Terminal Qty	2	4
Diagnostic Upload	Yes	
Hot Swap	Yes	
Isolation	Optocoupler isolation	
Static Working Current	≤200mA	

LED

PWR	Green: power supply is normal
IOL	Green: There is no communication connection with the IO-Link device.; Flashing green: The IO-Link device is connected normally.
CO	Green: power supply is normal
IO Signal LED	Green: Output is valid.; Off: No output/output short circuit.

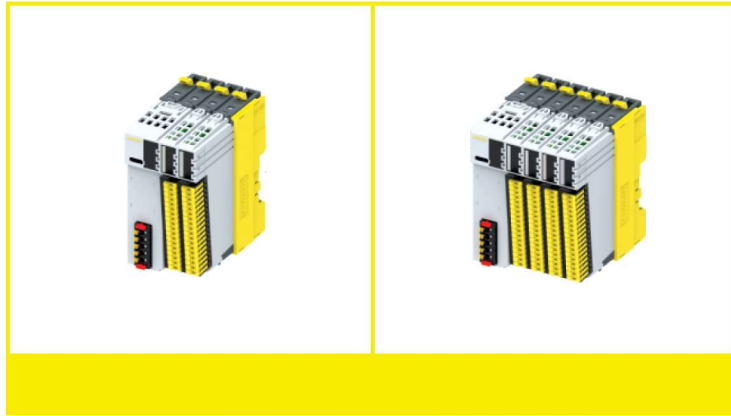

**IO-Link Device
Digital Input/Output Modules**

Features:

- Optocoupler isolation
- Compact size, saving more installation space
- Optional puncture-type and spring-type terminals to save wiring time
- Slot-type installation provides stable structure and faster response speed

Commercial Data

Order No.	Model	Specification
40001073	IOLD20E-PA-1616P	IO-Link Device, Digital Input/Output Module, 16/16, PNP, Spring Terminal
40001089	IOLD20E-PA-1616P/IDC	IO-Link Device, Digital Input/Output Module, 16/16, PNP, Input: IDC Terminal, Output: Spring Terminal
40001074	IOLD20E-PA-1616N	IO-Link Device, Digital Input/Output Module, 16/16, NPN, Spring Terminal
40001090	IOLD20E-PA-1616N/IDC	IO-Link Device, Digital Input/Output Module, 16/16, NPN, Input: IDC Terminal, Output: Spring Terminal
40001078	IOLD20E-PA-3232P	IO-Link Device, Digital Input/Output Module, 32/32, PNP, Spring Terminal
40001092	IOLD20E-PA-3232P/IDC	IO-Link Device, Digital Input/Output Module, 32/32, PNP, Input: IDC Terminal, Output: Spring Terminal
40001079	IOLD20E-PA-3232N	IO-Link Device, Digital Input/Output Module, 32/32, NPN, Spring Terminal
40001093	IOLD20E-PA-3232N/IDC	IO-Link Device, Digital Input/Output Module, 32/32, NPN, Input: IDC Terminal, Output: Spring Terminal

Basic Parameters

Model	IOLD20E-PA-1616P	IOLD20E-PA-1616N	IOLD20E-PA-3232P	IOLD20E-PA-3232N
Protection Level	IP20			
Dimension	104 × 61 × 48 mm			
Weight				
Operating Temperature	-25°C...70°C			
Operating Humidity	5%...95%			
Operating Atmospheric Pressure	80KPa...106KPa			

Output Type	Transistor output			
Polarity	PNP	NPN	PNP	NPN
Input/Output Channel	Input: 16 Output: 16		Input: 32 Output: 32	
Input "0" Signal	-3~5V DC	15~30V DC	-3~5V DC	15~30V DC
Input "1" Signal	15~30V DC	-3~5V DC	15~30V DC	-3~5V DC
Output Voltage	18...30V DC	0V DC	18...30V DC	0V DC
Current per Channel	0.5A/channel, 6A/module			
Load Type	Resistive load, Inductive load, Lamp load			
Software Filter Time (Input)	Yes			
Diagnostic Upload	Yes			
Hot Swap	Yes			
Overvoltage/short circuit protection	Yes			
Isolation	Optocoupler isolation			
Static Working Current	≤100mA			

LED

PWR	Green: power supply is normal
IOL	Green: There is no communication connection with the IO-Link device.; Flashing green: The IO-Link device is connected normally.
Input C0/C1	Green: power supply is normal
Output C0/C1	Power supply is normal/output overload
IO Signal LED	Green: The signal is valid.; Off: The signal is invalid/output short circuit.



IO-Link Device Analog Input Modules

Features:

- Optocoupler isolation
- Compact size, saving more installation space
- Optional puncture-type and spring-type terminals to save wiring time
- Slot-type installation provides stable structure and faster response speed

Commercial Data

Order No.	Model	Specification
40001080	IOLD20E-PA-AI8-I	IO-Link Device, Analog Input Modules, 8 channel, Current,diagnostic function, 0~20mA, 4~20mA
40001081	IOLD20E-PA-AI8-V	IO-Link Device, Analog Input Modules, 8 channel, Voltage,diagnostic function, 0~5V, 0~10V, 5~10V DC

Basic Parameters

Model	IOLD20E-PA-AI8-I	IOLD20E-PA-AI8-V
Protection Level	IP20	
Dimension	104 × 61 × 48 mm	
Weight		
Operating Temperature	-25°C...70°C	
Operating Humidity	5%...95%	
Operating Atmospheric Pressure	80KPa...106KPa	

Input Type	Analog Input	
Polarity	Current	Voltage
Input Channel	8	
Input Range	0~20mA; 4~20mA	0~5V; 0~10V; 5~10V DC
Input Error Range	< ±0.3%, full range	
Resolution	16 bit	
Measurement Display	0~65535	
Factory Setting	Channel default not used	
Ripple	< 1 %	
Terminal Qty	2	
Diagnostic Upload	Yes	
Hot Swap	Yes	
Overvoltage/short circuit protection	Yes	
Isolation	Optocoupler isolation	
Static Working Current	≤100mA	

LED

PWR	Green: power supply is normal
IOL	Green: There is no communication connection with the IO-Link device.; Flashing green: The IO-Link device is connected normally.
CO	Green: power supply is normal
IO Signal LED	Green: The channel is normal.; Red: The channel reports an error.



**IO-Link Device
Analog Output Modules**

Features:

- Optocoupler isolation
- Compact size, saving more installation space
- Optional puncture-type and spring-type terminals to save wiring time
- Slot-type installation provides stable structure and faster response speed

Commercial Data

Order No.	Model	Specification
40001084	IOLD20E-PA-AO8-I	IO-Link Device, Analog Output Modules, 4 channel, Current,diagnostic function, 0~20mA, 4~20mA
40001085	IOLD20E-PA-AO8-V	IO-Link Device, Analog Output Modules, 4 channel, Voltage,diagnostic function, 0~5V, 0~10V, 5~10V DC

Basic Parameters

Model	IOLD20E-PA-AO8-I	IOLD20E-PA-AO8-V
Protection Level	IP20	
Dimension	104 × 61 × 48 mm	
Weight		
Operating Temperature	-25°C...70°C	
Operating Humidity	5%...95%	
Operating Atmospheric Pressure	80KPa...106KPa	

Output Type	Analog Output	
	Current	Current Voltage
Output Channel	8	
Output Range	0~20mA; 4~20mA	0~5V; 0~10V; 5~10V DC
Output Error	<±0.3%, full range	
Resolution	16 bit	
Measurement Display	0~65535	
Factory Setting	Channel default not used	
Ripple	< 1 %	
Terminal Qty	2	
Diagnostic Upload	Yes	
Hot Swap	Yes	
Overvoltage/short circuit protection	Yes	
Isolation	Optocoupler isolation	
Static Working Current	≤100mA	

LED

PWR	Green: power supply is normal
IOL	Green: There is no communication connection with the IO-Link device.; Flashing green: The IO-Link device is connected normally.
CO	Green: power supply is normal
IO Signal LED	Green: The channel is normal.; Red: The channel reports an error.



IO-Link Device Temperature Measurement Modules

Features:

- Optocoupler isolation
- Compact size, saving more installation space
- Optional puncture-type and spring-type terminals to save wiring time
- Slot-type installation provides stable structure and faster response speed

Commercial Data

Order No.	Model	Specification
40001082	IOLD20E-PA-AI8-TC	IO-Link Device, Temperature Measurement, 4 channel, Thermocouple diagnostic function, J/K/E/N/R/S/B/T
40001083	IOLD20E-PA-AI8-PT	IO-Link Device, Temperature Measurement, 4 channel, Thermal Resistance diagnostic function, PT100/PT500/PT1000

Basic Parameters

Model	IOLD20E-PA-AI8-TC	IOLD20E-PA-AI8-PT
Protection Level	IP20	
Dimension	104 × 61 × 48mm	
Weight		
Operating Temperature	-25°C...70°C	
Operating Humidity	5%...95%	
Operating Atmospheric Pressure	80KPa...106KPa	



Technical Data

Input Type	Thermocouple	Thermal Resistance
Input Channel	8	
Input Type	J/K/E/N/R/S/B/T	PT100/PT500/PT1000
Wiring Type	Two-wire	Two-wire/Three-wire/Four-wire
Filter Time	0S-10S(Default: 0)	
Resolution	16 bit	
Range Error	J/E/N/R/S/B: < ±2°C K: < ±2°C T: -200~0°C < ±7% 0~400°C < ±2%	Two-wire: < ±0.3% Others: < ±0.2%
Function Setting	Disconnection detection (value cleared after disconnection) Measure up and down detection Upper and lower threshold settings	
Terminal Qty	2	
Diagnostic Upload	Yes	
Factory Setting	Channel default not used	
Hot Swap	Yes	
Overvoltage/short circuit protection	Yes	
Isolation	Optocoupler isolation	
Static Working Current	≤100mA	

LED

PWR	Green: power supply is normal
IOL	Green: There is no communication connection with the IO-Link device.; Flashing green: The IO-Link device is connected normally.
CO	Green: power supply is normal

Model	TC-01
Part Picture	
Order No.	40001474
Description	MT20E Vacant slots cover
Apply to	MT20E
Dimension	104 × 61 × 12 mm

Model	DZ-16S	DZ-16I
Part Picture		
Order No.	40001470	40001471
Description	Spring type (max 1.5mm ²)	IDC type (0.25~0.5mm ²)
Dimension	69 × 17 × 12 mm	

Model	TC-L1	TC-R1
Part Picture		
Order No.	40001472	40001473
Description	End cover(Front)	End cover(Rear)
Apply to	MT20E	



MT20S Series Module



Profinet Coupler Modules

Features:

- 2 RJ45 interfaces, 100Mbit/s
- Expandable with 32 different S-series modules
- Compact size, saving more installation space
- Terminals are removable and support tool-less installation
- Internal bus speed up to 100Mbps

Commercial Data

Order No.	Model	Specification
40002000	MT20S-PN-GW	MT20S Coupler Modules, Profinet, DC24V

Basic Parameters

Model	MT20S-PN-GW
Protection Level	IP20
Coupler Size	104 × 61 × 24mm
Weight	
Operating Temperature	-25°C...70°C
Operating Humidity	5%...95%
Operating Atmospheric Pressure	80KPa...106KPa

Technical Data

Physical Layer	Ethernet
Transfer Speed	10/100 Mbps, full duplex
Protocol	Profinet
Minimum Cycle Time	1ms
Communication Interface	2 × RJ45
Internal Bus Speed	up to 100Mbps
Diagnostic Upload	Yes
System Power Supply	18...30 VDC (type.24VDC)
Total Current	≤6A
Static Working Current	≤150mA
Short Circuit/Reverse Conn. Protection	Yes
Firmware Upgrade	Yes
Hot Swap	Yes
Isolation	Optocoupler isolation

LED

PWR	Green: Normal power supply; Red: Undervoltage/overvoltage
BF	Off: Normal; Flashing red: Configuration/network abnormality
SF	Off: Normal; Red light: System failure
MOD	Green: Normal; Red: Expansion module configuration is inconsistent/Extension module is abnormal
RUN	Extension modules are running normally
ERR	There is an error when running the extension module



EtherCAT Coupler Modules

Features:

- 2 RJ45 interfaces, 100Mbit/s
- Expandable with 32 different S-series modules
- Compact size, saving more installation space
- Terminals are removable and support tool-less installation
- Internal bus speed up to 100Mbps

Commercial Data

Order No.	Model	Specification
40002001	MT20S-EC-GW	MT20S Coupler Modules , EtherCAT, DC24V

Basic Parameters

Model	MT20S-EC-GW
Protection Level	IP20
Coupler Size	104 × 61 × 24mm
Weight	
Operating Temperature	-25°C...70°C
Operating Humidity	5%...95%
Operating Atmospheric Pressure	80KPa...106KPa

Technical Data

Physical Layer	Ethernet
Transfer Speed	10/100 Mbps, full duplex
Protocol	EtherCAT
Minimum Cycle Time	1ms
Communication Interface	2 × RJ45
Internal Bus Speed	up to 100Mbps
Diagnostic Upload	Yes
System Power Supply	18...30 VDC (type.24VDC)
Total Current	≤6A
Static Working Current	≤150mA
Short Circuit/Reverse Conn. Protection	Yes
Firmware Upgrade	Yes
Hot Swap	Yes
Isolation	Optocoupler isolation

LED

PWR	Green: Normal power supply; Red: Undervoltage/overvoltage
RUN	Green: The module is normal; Flashing green slowly: SAFEOP; Flashing green quickly: Pre-OP.
ERR	Off: Normal; Flashing red: Communication abnormality



Ethernet/IP Coupler Modules

Features:

- 2 RJ45 interfaces, 100Mbit/s
- Expandable with 32 different S-series modules
- Compact size, saving more installation space
- Terminals are removable and support tool-less installation
- Internal bus speed up to 100Mbps

Commercial Data

Order No.	Model	Specification
40002002	MT20S-EI-GW	MT20S Coupler Modules, Ethernet/IP, DC24V

Basic Parameters

Model	MT20S-EC-GW
Protection Level	IP20
Coupler Size	104 × 61 × 24mm
Weight	
Operating Temperature	-25°C...70°C
Operating Humidity	5%...95%
Operating Atmospheric Pressure	80KPa...106KPa

Technical Data

Physical Layer	Ethernet
Transfer Speed	10/100 Mbps, full duplex
Protocol	Ethernet/IP
Minimum Cycle Time	1ms
Communication Interface	2 × RJ45
Internal Bus Speed	up to 100Mbps
Diagnostic Upload	Yes
System Power Supply	18...30 VDC (type.24VDC)
Total Current	≤6A
Static Working Current	≤150mA
Short Circuit/Reverse Conn. Protection	Yes
Firmware Upgrade	Yes
Hot Swap	Yes
Isolation	Optocoupler isolation

LED

PWR	Green: Normal power supply; Red: Undervoltage/overvoltage
MS	Green: Normal; Flashing green: The module is not configured; Red: Module fault
NS	Green: The network is normal.; Flashing green: Communication is not established.; Flashing red: Communication is interrupted.
MOD	Green: Normal; Red: Expansion module configuration is inconsistent/Extension module is abnormal
RUN	Extension modules are running normally
ERR	There is an error when running the extension module

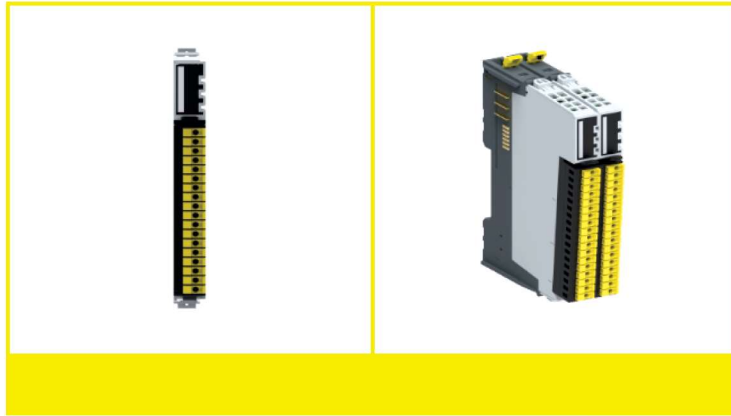

Digital Input Modules

Features:

- Optocoupler isolation
- Stable connection
- Compact size, saving more installation space
- Optional puncture-type and spring-type terminals to save wiring time

Commercial Data

Order No.	Model	Specification
40002050	S-1600C	S series Digital Input Modules, 16channel, PNP/NPN 24VDC, diagnostic function, Spring Terminal
40002068	S-1600C/IDC	S series Digital Input Modules, 16channel, PNP/NPN 24VDC, diagnostic function, IDC Terminal
40002056	S-3200C	S series Digital Input Modules, 32channel, PNP/NPN 24VDC, diagnostic function, Spring Terminal
40002074	S-3200C/IDC	S series Digital Input Modules, 32channel, PNP/NPN 24VDC, diagnostic function, IDC Terminal

Basic Parameters

Model	S-1600C	S-3200C
Protection Level	IP20	
Coupler Size	104 × 61 × 12mm	104 × 61 × 24mm
Weight		
Operating Temperature	-25°C...70°C	
Operating Humidity	5%...95%	
Operating Atmospheric Pressure	80KPa...106KPa	

Technical Data

Input Type	Digital	
Polarity	PNP/NPN	
Input Channel	16	32
"0" Signal	PNP : -3~5V NPN : 15~30V	
"1" Signal	PNP : 15~30V NPN : -3~5V	
Software Filter Time	Yes	
Diagnostic Upload	Yes	
Hot Swap	Yes	
Overvoltage/short circuit protection	Yes	
Isolation	Optocoupler isolation	
Static Working Current	≤100mA	

LED

C0	Green: Channel A0...Channel A7 COM power supply is normal
C1	Green: Channel B0...Channel B7 COM power supply is normal
IO Signal LED	Green: input is valid



Digital Output Modules

Features:

- Optocoupler isolation
- Stable connection
- Compact size, saving more installation space
- Optional puncture-type and spring-type terminals to save wiring time

Commercial Data

Order No.	Model	Specification
40002051	S-0016P	S series Digital Output Modules, 16channel, PNP, 24VDC, diagnostic function, Spring Terminal
40002069	S-0016P/IDC	S series Digital Output Modules, 16channel, PNP, 24VDC, diagnostic function, IDC Terminal
40002052	S-0016N	S series Digital Output Modules, 16channel, NPN, 24VDC, diagnostic function, Spring Terminal
40002070	S-0016N/IDC	S series Digital Output Modules, 16channel, NPN, 24VDC, diagnostic function, IDC Terminal
40002053	S-0008R	S series Digital Output Modules, 8channel, Relay, 125V AC/30V DC, diagnostic function

Basic Parameters

Model	S-0016P	S-0016N	S-0008R
Protection Level	IP20		
Dimension	104 × 61 × 12 mm		
Weight			
Operating Temperature	-25°C...70°C		
Operating Humidity	5%...95%		
Operating Atmospheric Pressure	80KPa...106KPa		

Technical Data

Output Type	Transistor output		Relay output
Polarity	PNP	NPN	Relay output
Output Channel	16		8
Output Voltage	18...30V DC	0V DC	125V AC/30V DC
Current per Channel	0.5A/channel, 6A/module		2A/channel, 8A/module
Switch Lifetime	---		0.1 million times
Load Type	Resistive load, Inductive load, Lamp load		
Diagnostic Upload	Yes		
Hot Swap	Yes		
Overvoltage/short circuit protection	Yes		---
Isolation	Optocoupler isolation		
Static Working Current	≤100mA		

LED

C0	Green: Power supply is normal
C1	Output overload
IO Signal LED	Green: Output is valid; Off: No output/output short circuit.

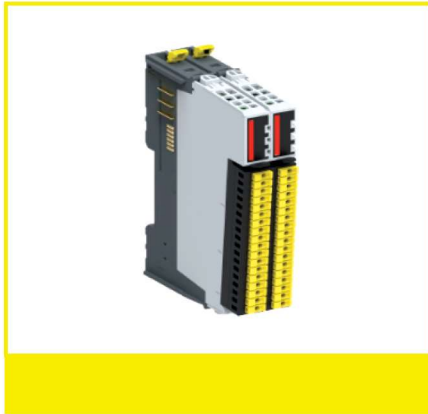

32channel Digital Output Modules

Features:

- Optocoupler isolation
- Stable connection
- Compact size, saving more installation space
- Optional puncture-type and spring-type terminals to save wiring time

Commercial Data

Order No.	Model	Specification
40002057	S-0032P	S series Digital Output Modules, 32channel, PNP, 24VDC, diagnostic function, Spring Terminal
40002075	S-0032P/IDC	S series Digital Output Modules, 32channel, PNP, 24VDC, diagnostic function, IDC Terminal
40002058	S-0032N	S series Digital Output Modules, 32channel, NPN, 24VDC, diagnostic function, Spring Terminal
40002076	S-0032N/IDC	S series Digital Output Modules, 32channel, NPN, 24VDC, diagnostic function, IDC Terminal

Basic Parameters

Model	S-0032P	S-0032N
Protection Level	IP20	
Dimension	104 × 61 × 24mm	
Weight		
Operating Temperature	-25°C...70°C	
Operating Humidity	5%...95%	
Operating Atmospheric Pressure	80KPa...106KPa	

Technical Data

Output Type	Digital Output (Transistor)	
Polarity	PNP	NPN
Output Channel	32	
Output Voltage	18...30V DC	0V DC
Current per Channel	0.5A/channel, 6A/module	
Load Type	Resistive load, Inductive load, Lamp load	
Diagnostic Upload	Yes	
Hot Swap	Yes	
Overvoltage/short circuit protection	Yes	
Isolation	Optocoupler isolation	
Static Working Current	≤100mA	

LED

C0	Green: power supply is normal
C1	Output overload
IO Signal LED	Green: Output is valid.; Off: No output/output short circuit.



16 channel Digital Input/Output Modules

Features:

- Optocoupler isolation
- Stable connection
- Compact size, saving more installation space
- Optional puncture-type and spring-type terminals to save wiring time

Commercial Data

Order No.	Model	Specification
40002054	S-0808P	S series Digital Input/Output Module, 16channel, PNP, 24VDC, diagnostic function
40002055	S-0808N	S series Digital Input/Output Module, 16channel, NPN, 24VDC, diagnostic function

Basic Parameters

Model	S-0808P	S-0808N
Protection Level	IP20	
Dimension	104 × 61 × 12mm	
Weight		
Operating Temperature	-25°C...70°C	
Operating Humidity	5%...95%	
Operating Atmospheric Pressure	80KPa...106KPa	

Technical Data

Signal Type	Digital Input/Output	
Polarity	PNP	NPN
Input/Output Channel	Input: 8 Output: 8	
Input "0" Signal (A0..A7)	-3~5V	15~30V
Input "1" Signal (A0..A7)	15~30V	-3~5V
Output Voltage (B0..B7)	18...30V DC	0V DC
Current per Channel (B0..B7)	0.5A/channel, 6A/module	
Load Type (B0..B7)	Resistive load, Inductive load, Lamp load	
Software Filter Time (A0..A7)	Yes	
Diagnostic Upload	Yes	
Hot Swap	Yes	
Overvoltage/short circuit protection	Yes	
Isolation	Optocoupler isolation	
Static Working Current	≤100mA	

LED

Input C0/C1	Green: power supply is normal
Output C0/C1	Power supply is normal/output overload
IO Signal LED	Green: The signal is valid.; Off: The signal is invalid/output short circuit.

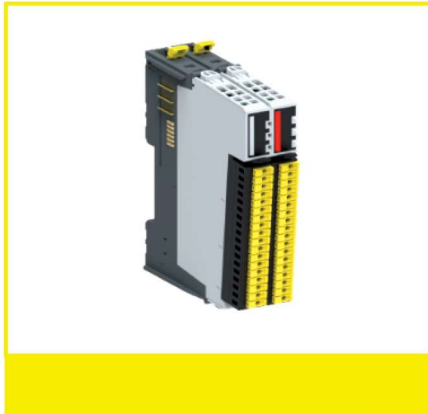

32channel Digital Input/Output Modules

Features:

- Optocoupler isolation
- Stable connection
- Compact size, saving more installation space
- Optional puncture-type and spring-type terminals to save wiring time

Commercial Data

Order No.	Model	Specification
40002059	S-1616P	S series Digital Input/Output Module, 32channel, PNP, 24VDC, diagnostic function
40002060	S-1616N	S series Digital Input/Output Module, 32channel, NPN, 24VDC, diagnostic function

Basic Parameters

Model	S-1616P	S-1616N
Protection Level	IP20	
Dimension	104 × 61 × 24mm	
Weight		
Operating Temperature	-25°C...70°C	
Operating Humidity	5%...95%	
Operating Atmospheric Pressure	80KPa...106KPa	

Technical Data

Signal Type	Digital Input/Output	
Polarity	PNP	NPN
Input/Output Channel	Input: 16 Output: 16	
Input "0" Signal (A0..A7)	-3~-5V	15~30V
Input "1" Signal (A0..A7)	15~30V	-3~-5V
Output Voltage (B0..B7)	18...30V DC	0V DC
Current per Channel (B0..B7)	0.5A/channel, 6A/module	
Load Type (B0..B7)	Resistive load, Inductive load, Lamp load	
Software Filter Time (A0..A7)	Yes	
Diagnostic Upload	Yes	
Hot Swap	Yes	
Overvoltage/short circuit protection	Yes	
Isolation	Optocoupler isolation	
Static Working Current	≤100mA	

LED

Input C0/C1	Green: power supply is normal
Output C0/C1	Power supply is normal/output overload
IO Signal LED	Green: The signal is valid.; Off: The signal is invalid/output short circuit.



Analog Modules

Features:

- Optocoupler isolation
- Stable connection
- Compact size, saving more installation space
- Optional puncture-type and spring-type terminals to save wiring time

Commercial Data

Order No.	Model	Specification
40002061	S-AIO4-VI	S series Analog Modules, 4channel, current/voltage, diagnostic function, 0~20mA, 4~20mA, 0~5V, 0~10V, 5~10V DC
40002062	S-AIO8-VI	S series Analog Modules, 8channel, current/voltage, diagnostic function, 0~20mA, 4~20mA, 0~5V, 0~10V, 5~10V DC

Basic Parameters

Model	S-AIO4-VI	S-AIO8-VI
Protection Level	IP20	
Dimension	104 × 61 × 12mm	
Weight		
Operating Temperature	-25°C...70°C	
Operating Humidity	5%...95%	
Operating Atmospheric Pressure	80KPa...106KPa	

Technical Data

Input/Output Type	Analog Input/Output	
Input/Polarity	Current Voltage input/output	
Analog Channel	4	8
Input/Output Range (Current)	0~20mA; 4~20mA	
Input/Output Range (Voltage)	0~5V; 0~10V; 5~10V DC	
Configuration Function	each channel input/output, current/voltage can be configured individually	
Input/Output Error	< ±0.3%, full range	
Resolution	16 bit	
Measurement Display	0~65535	
Factory Setting	Channel default not used	
Ripple	< 1 %	
Diagnostic Upload	Yes	
Hot Swap	Yes	
Overvoltage/short circuit protection	Yes	
Isolation	Optocoupler isolation	
Static Working Current	≤100mA	

LED

C0	Operating normally
C1	Operating abnormally
A1...A8	Corresponding port signal is normal
B1...B8	Corresponding port signal is abnormal



Temperature Measurement Modules

Features:

- Optocoupler isolation
- Stable connection
- Compact size, saving more installation space
- Optional puncture-type and spring-type terminals to save wiring time

Commercial Data

Order No.	Model	Specification
40002063	S-AI4-TR	S series Temperature Measurement, 4channel, Thermocouple,Thermal Resistance diagnostic function, J/K/E/N/R/S/B/T/PT100/PT500/PT1000

Basic Parameters

Model	S-AI4-TR
Protection Level	IP20
Dimension	104 × 61 × 12mm
Weight	
Operating Temperature	-25°C...70°C
Operating Humidity	5%...95%
Operating Atmospheric Pressure	80KPa...106KPa

Technical Data

Input Type	Thermocouple/Thermal Resistance	
Input Channel	4	
Input Type	J/K/E/N/R/S/B/T/PT100/PT500/PT1000	
Type	Two-wire/Three-wire/Four-wire	
Filter Time	0S-10S(Default: 0)	
Resolution	16 bit	
Range Error	J/E/N/R/S/B: < ±2°C K: < ±2°C T: -200~0°C < ±7% 0~400°C < ±2%	PT100/PT500/PT1000 Two-wire: < ±0.3% Others: < ±0.2%
Function Setting	Disconnection detection (value cleared after disconnection) Measure up and down detection Upper and lower threshold settings	
Diagnostic Upload	Yes	
Factory Setting	Channel default not used	
Hot Swap	Yes	
Overvoltage/short circuit protection	Yes	
Isolation	Optocoupler isolation	
Static Working Current	≤100mA	

LED

C0	Operating normally
C1	Operating abnormally
A1...A4	Corresponding port signal is normal
B1...B4	Corresponding port signal is abnormal



Serial Modules

Features:

- Optocoupler isolation
- Stable connection
- Compact size, saving more installation space
- Optional puncture-type and spring-type terminals to save wiring time

Commercial Data		
Order No.	Model	Specification
40002064	S-1COM	S series Serial Modules, 1channel, RS485/RS422/RS232

Basic Parameters	
Model	S-1COM
Protection Level	IP20
Dimension	104 × 61 × 12mm
Weight	
Operating Temperature	-25°C...70°C
Operating Humidity	5%...95%
Operating Atmospheric Pressure	80KPa...106KPa

Technical Data	
Communication Interface	RS232/RS485/RS422
Channels	1
Protocol	Modbus RTU, Modbus ASCII
Baud Rate	4800bit/s, 9600bit/s, 19200 bit/s, 38400 bit/s, 57600 bit/s, 115200 bit/s
Data Bits	7 or 8 bits, default is 8 bits
Start Bit	fixed to 1
Stop Bit	1 or 2, default is 1
Check Bit	odd parity/even parity/no parity, the default is even parity
Device Qty	In RS485 mode, it supports up to 31 Modbus devices. In RS232/RS422 mode, only one Modbus device can be supported.
Communication Distance	RS232: ≤15m RS422/RS485: ≤1200m
Terminal Matching Resistor	Through the user's external wiring selection, short-circuit the near end of the terminal resistor port.
Hot Swap	Not available
Static Working Current	≤100mA@5VDC

LED	
C0	Operating normally
C1	Operating abnormally
TX0/RX0	Flashing: Data is being sent/received.; Off: No data.
TX1/RX1	Flashing: Data is being sent/received.; Off: No data.



Encoder Input Modules

Features:

- Optocoupler isolation
- Stable connection
- Compact size, saving more installation space
- Optional puncture-type and spring-type terminals to save wiring time

Commercial Data

Order No.	Model	Specification
40002065	S-2SSI	S series Encoder SSI Input Modules, 2channel, differential

Basic Parameters

Model	S-2SSI
Protection Level	IP20
Dimension	104 × 61 × 12mm
Weight	
Operating Temperature	-25°C...70°C
Operating Humidity	5%...95%
Operating Atmospheric Pressure	80KPa...106KPa

Technical Data

Communication Interface	SSI
Channels	2
Encoder Signal Type	differential, 5V
SSI Encoder Clock Frequency	≤2MHz
Signal Type	Binary/Gray code, default is Gray code
Data Frame Length	10~40 Bit
Position Value LSB/MSB	configurable
Encoder Disconnected	encoder output value is set to 0
Overvoltage/short circuit protection	Yes
Terminal Power Output Voltage	2 channels of 24V output
Terminal Power Output Current	500mA/port
Hot Swap	not available
Static Working Current	≤100mA

LED

C0	Operating normally
C1	Operating abnormally
CH1	Always on: the encoder is valid.; Constantly off: the encoder is invalid
CH2	Always on: the encoder is valid.; Constantly off: the encoder is invalid



Power Relay Module

Features:

- Stable connection
- Compact size, saving more installation space
- Optional puncture-type and spring-type terminals to save wiring time

Commercial Data

Order No.	Model	Specification
40002067	S-POWER	Power Relay Module, 24VDC Power Relay, supplies power to expansion modules and does not occupy slots

Basic Parameters



Model	S-POWER
Protection Level	IP20
Dimension	104 × 61 × 12mm
Weight	
Operating Temperature	-25°C...70°C
Operating Humidity	5%...95%
Operating Atmospheric Pressure	80KPa...106KPa

Technical Data

Input Voltage	24V DC
---------------	--------

LED

PWR	Power supply is normal
-----	------------------------

Model	DZ-16S	DZ-16I
Part Picture		
Order No.	40001470	40001471
Description	Spring type (max 1.5mm ²)	IDC type (0.25~0.5mm ²)
尺寸	69 × 17 × 12 mm	

Model	TC-L1	TC-R1
Part Picture		
Order No.	40001472	40001473
Description	End cover(Front)	End cover(Rear)
Apply to	MT20S	



RFID Series

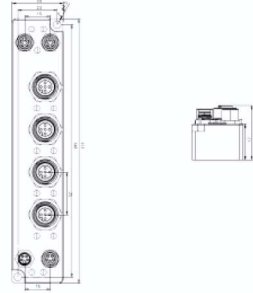

MT67MC series IOLINK bus module provides standard industrial IOLINK bus protocol RFID controller, support ProfiNet, EtherCAT, Ethernet/IP agreements. The transmission rate of industrial Ethernet supports up to 100Mbps, and multiple sets of bus modules can be cascaded into the PLC to provide powerful on-site data collection capabilities. The shell is made of strong zinc alloy metal material, which has the characteristics of connection range, strong communication ability, good environment adaptation and high Protection Level.

Specification

Model	MT67MC-PN-IOLM4A	MT67MC-EC-IOLM4A	MT67MC-EC-IOLM4A
Dimensions	140.0 * 63.0 * 31.4mm		
Material of Shell	Aluminium alloy		
Rated Voltage	18~30Vpc		
Rated Current	MAX≤ 0.15A@24V		
Power Port	A-CODE Male/Female 4Pin		
Power supply protection	Reverse protection		

Communication parameters

Protocol	ProfiNet	EtherCAT	EtherNet/IP
EtherNet Port	M8 A-CODE Female, 4Pin		
System topology	Star structure, Tree structure		
Communication Port	M8 A-CODE Female, 4Pin		

Radio frequency (RF) parameters

RFID Channel	IO-Link Channel × 4
RFID Port	A-CODE M12 5PIN Female
Load capacity	VOUT=24V±20%, IOOUT ≤ 1.6A
Circuit protection	Reverse protection, Overvoltage protection

Enironmental adaptation

Operating temperature	-25C~ +70°C
Storage temperature	-40°C~ +85°C
Humidness	5%~95%RH(no condensation)
Protection Level	IP67
Ant-Vibration	IEC60068-2
Free drop test	According to IEC60068-32
EMC	According to IEC61000-4-2,-3,-4



The MRF-HM18-IOL01 product is a precision, all-in-one industrial RFID Read/Write Device that supports IOLINK Protocol. It is fixed with 2 M18 nuts, and the size is small, which is suitable for automatic identification scenes with high size requirements and precision manufacturing links.



Specification

Model	MRF-HM18-IOL01
Distance to read	0-40mm(Related to Labels)
Communication Port	IO-LINK
Protocol	IO-LINK
Communication rate	COM3: 230.4KBps
Voltage	24VDC
Current	<30mA@24VDC
LED	2 × LED

Physical parameters

Dimensions	M18 x 72.5mm
Port	M12 A-code
Fixed type	Screw, M18*1.5
Housing material	Nickel plated brass+ABS
Housing color	Silver + Yellow
Weight	30g

Radio frequency (RF) parameters

Protocol	ISO 15693
Operating frequency	13.56MHz
Output power	23 dBm
Wireless rate	26.48Kbit/s

Enironmental adaptation

Operating temperature	-20C~+70°C
Storage temperature	-25°C~+85°C
Humidness	5%~95%RH(no condensation)
Protection Level	IP67
Ant-Vibration	IEC60068-2
Free drop test	According to IEC60068-32
EMC	According to IEC61000-4-2,-3,-4

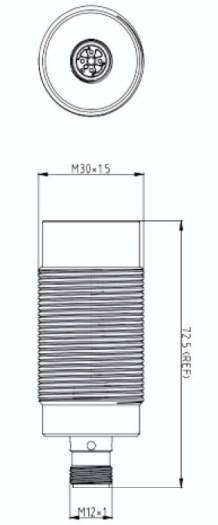

The MRF-HM30-IOL01 product is a precision, all-in-one industrial grade RFID Read/Write Device that supports IOLINK Protocol. It is fixed with 2 M30 nuts, which is suitable for automatic identification of precision manufacturing links with high size requirements.

Specification

Model	MRF-HM30-IOL01
Distance to read	0-60mm(Related to Labels)
Communication Port	IO-LINK
Protocol	IO-LINK
Communication rate	COM3: 230.4KBps
Voltage	24VDC
Current	<30mA@24VDC
LED	2 × LED

Physical parameters

Dimensions	M30 x 72.5mm
Port	M12 A-code
Fixed type	Screw, M30*1.5
Housing material	Nickel plated brass+ABS
Housing color	Silver + Yellow
Weight	70g

Radio frequency (RF) parameters

Protocol	ISO 15693
Operating frequency	13.56MHz
Output power	23 dBm
Wireless rate	26.48Kbit/s

Enironmental adaptation

Operating temperature	-20C~+70°C
Storage temperature	-25°C~+85°C
Humidness	5%~95%RH(no condensation)
Protection Level	IP67
Ant-Vibration	IEC60068-2
Free drop test	According to IEC60068-32
EMC	According to IEC61000-4-2,-3,-4

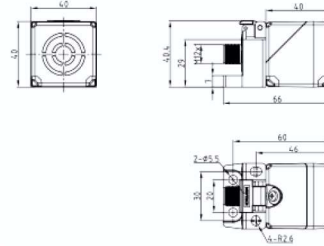

The MRF-HQ40-IOL01 product is a high frequency integrated industrial RFID Read/Write Device that supports IOLINK Protocol. Using 2 M5 screws to fix, this Series product has good reading performance, long distance and high Protection Level, which is suitable for automated production process in all walks of life.

Specification

Model	MRF-HQ40-IOL01
Distance to read	0-60mm(Related to Labels)
Communication Port	IO-LINK
Protocol	IO-LINK
Communication rate	COM3: 230.4KBps
Voltage	24VDC
Current	<30mA@24VDC
LED	2 × LED

Physical parameters

Dimensions	40 x 40 x 66mm
Port	M12 A-code
Fixed type	2 M5 screw holes
Housing material	PBT
Housing color	Yellow + Black
Weight	120g

Radio frequency (RF) parameters

Protocol	ISO 15693
Operating frequency	13.56MHz
Output power	23 dBm
Wireless rate	26.48Kbit/s

Enironmental adaptation

Operating temperature	-20C~+70°C
Storage temperature	-25°C~+85°C
Humidness	5%~95%RH(no condensation)
Protection Level	IP67
Ant-Vibration	IEC60068-2
Free drop test	According to IEC60068-32
EMC	According to IEC61000-4-2,-3,-4

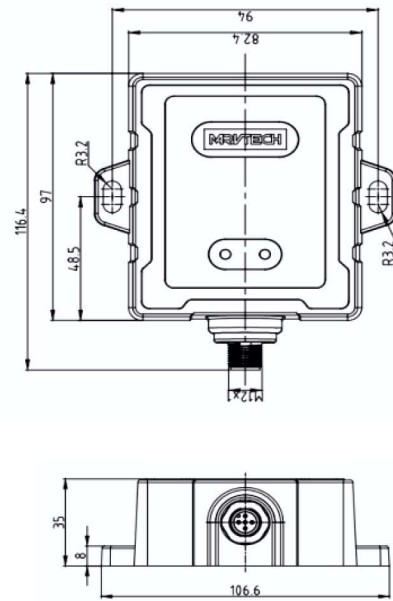

The MRF-HQ80-IOL01 product is a high frequency integrated industrial RFID Read/Write Device that supports IOLINK Protocol. Using 2 M6 screws to fix, this Series product has good reading performance, long distance, high Protection Level, and is suitable for automated production process in all walks of life.

Specification

Model	MRF-HQ80-IOL01
Distance to read	0-110mm(Related to Labels)
Communication Port	IO-LINK
Protocol	IO-LINK
Communication rate	COM3: 230.4KBps
Voltage	24VDC
Current	<30mA@24VDC
LED	2 × LED

Physical parameters

Dimensions	80 x 80 x 35mm
Port	M12 A-code
Fixed type	2 M6 screw holes
Housing material	PBT
Housing color	Yellow
Weight	380g

Radio frequency (RF) parameters

Protocol	ISO 15693
Operating frequency	13.56MHz
Output power	23 dBm
Wireless rate	26.48Kbit/s

Enironmental adaptation

Operating temperature	-20C~+70°C
Storage temperature	-25°C~+85°C
Humidness	5%~95%RH(no condensation)
Protection Level	IP67
Ant-Vibration	IEC60068-2
Free drop test	According to IEC60068-32
EMC	According to IEC61000-4-2,-3,-4

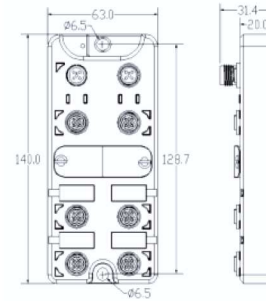

MT67ML Series bus module An RFID controller that provides standard industrial bus protocols, supporting ProfiNet, EtherCAT, Ethernet/IP, MODBUS TCP protocols. The transmission rate of industrial Ethernet supports up to 100Mbps, and multiple sets of bus modules can be cascaded into the PLC to provide powerful on-site data collection capabilities.

Specification

Model	MT67ML-PN-4RF	MT67ML-EC-4RF	MT67ML-EIP-4RF	MT67ML-EN-4RF
Dimensions	140.0*63.0*31.4mm			
Material of Shell	Zinc alloy			
Rated Voltage	18~30Vpc			
Rated Current	MAX<=0.3A@24V			
Power Port	T-CODE Male/Female 4Pin			
Power supply protection	Reverse protection			

Communication parameters

Protocol	ProfiNet	EtherCAT	EtherNet/IP	MODBUS TCP
EtherNet Port	Both dual network ports integrate switch functions			Single network port
System topology	Star structure, Tree structure			Star structure
Communication Port	D-CODE M12 Female, 4Pin			

Radio frequency (RF) parameters

RFID Channel	RS485 Channel × 4
RFID Port	A-CODE M12 5PIN Female
Load capacity	VOUT=24V±20%, IOOUT<=0.7A
Circuit protection	Reverse protection, Overvoltage protection

Enironmental adaptation

Operating temperature	-25C~+70°C
Storage temperature	-40°C~+85°C
Humidness	5%~95%RH(no condensation)
Protection Level	IP67
Ant-Vibration	2 mm (f= 5...29.5 Hz), EN 60068-2-6 7 gn(f=29.5....150Hz), EN 60068-2-6
ESD	Contact discharge, 8KV, over class A Air discharge, 15KV, over Class A IEC 61000-4-2

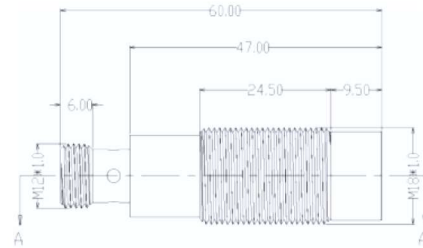

The MRF-HM18 product is a precision, all-in-one industrial grade RFID Read/Write Device that supports RS485 and uses standard MODBUS Protocol. Using 2 M18 nuts to fix, small and diverse size, suitable for high size requirements, precision manufacturing links automatic identification scene.

Specification

Model	MRF-HM18
Distance to read	0-30mm(Related to Labels)
Communication Port	RS485
Protocol	MODBUS RTU
Communication rate	9600~115200 bits/s
Voltage	9~30VDC
Current	<0.05A@24VDC
LED	1 × LED

Physical parameters

Dimensions	M18 x 60mm
Port	M12 A-code, Male
Fixed type	Screw, M18*1.0
Housing material	Stainless steel +ABS
Housing color	Silver + Black
Weight	30g

Radio frequency (RF) parameters

Protocol	ISO 15693、ISO 14443A
Operating frequency	13.56MHz
Output power	27.5 dBm
Wireless rate	26.48Kbit/s

Enironmental adaptation

Operating temperature	-20C~+70°C
Storage temperature	-25°C~+85°C
Humidness	5%~95%RH(no condensation)
Protection Level	IP67
Ant-Vibration	2 mm (f= 5...29.5 Hz) , EN 60068-2-6,7 gn (f= 29.5...150 Hz) , EN 60068-2-6
Conducted immunity (CS)	10V, IEC 61000-4-6
ESD	Contact discharge, 8KV, air discharge, 15KV, IEC 61000-4-2

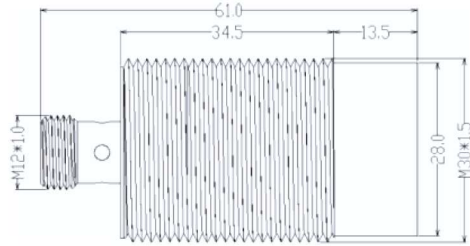

The MRF-HM30 product is a precision, all-in-one industrial grade RFID Read/Write Device that supports RS485 and uses standard MODBUS Protocol. It is fixed with 2 M30 nuts, which is suitable for automatic identification of precision manufacturing links with high size requirements.

Specification

Model	MRF-HM30
Distance to read	0-60mm(Related to Labels)
Communication Port	RS485
Protocol	MODBUS RTU
Communication rate	9600~115200 bits/s
Voltage	9~30VDC
Current	<0.05A@24VDC
LED	1 × LED

Physical parameters

Dimensions	M30 x 61mm
Port	M12 A-code, Male
Fixed type	Screw, M38*1.5
Housing material	Stainless steel +ABS
Housing color	Silver + Black
Weight	70g

Radio frequency (RF) parameters

Protocol	ISO 15693、ISO 14443A
Operating frequency	13.56MHz
Output power	27.5 dBm
Wireless rate	26.48Kbit/s

Enironmental adaptation

Operating temperature	-20C~+70°C
Storage temperature	-25°C~+85°C
Humidness	5%~95%RH(no condensation)
Protection Level	IP67
Ant-Vibration	2 mm (f= 5...29.5 Hz) , EN 60068-2-6,7 gn (f= 29.5...150 Hz) , EN 60068-2-6
Conducted immunity (CS)	10V, IEC 61000-4-6
ESD	Contact discharge, 8KV, air discharge, 15KV, IEC 61000-4-2

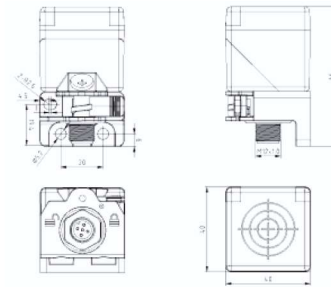

The MRF-HQ40 product is a high frequency integrated industrial RFID Read/Write Device that supports RS485 or Ethernet and can use standard MODBUS Protocol. Using 2 M5 nuts to fix, this Series product has good reading performance, long distance and high Protection Level, which is suitable for automated production process in all walks of life.

Specification

Model	MRF-HQ40	MRF-HQ40-TP
Distance to read	0~60mm(Related to Labels)	
Communication Port	RS485	MODBUS TCP
Protocol	MODBUS RTU	MODBUS TCP
Communication rate	9600~115200 bits/s	10M/100M self-adaptation
Voltage	9-30VDC	
Current	<0.07A@24VDC	
LED	4 × LED	

Physical parameters

Dimensions	40x40x66mm	
Port	M12 Acode 5PIN Male	M12 Acode 8PIN Male
Fixed type	2 M5 screw holes	
Housing material	PC+ABS	
Housing color	Black + Blue	
Weight	100g	

Radio frequency (RF) parameters

Protocol	ISO 15693、ISO 14443A
Operating frequency	13.56MHz
Output power	27.5dBm
Wireless rate	26.48Kbit/s

Enironmental adaptation

Operating temperature	-20C~+70°C
Storage temperature	-25°C~+85°C
Humidness	5%~95%RH(no condensation)
Protection Level	IP67
Ant-Vibration	2 mm (f= 5...29.5 Hz) , EN 60068-2-6,7 gn (f= 29.5...150 Hz) , EN 60068-2-6
Conducted immunity (CS)	10V, IEC 61000-4-6
ESD	Contact discharge, 8KV, air discharge, 15KV, IEC 61000-4-2

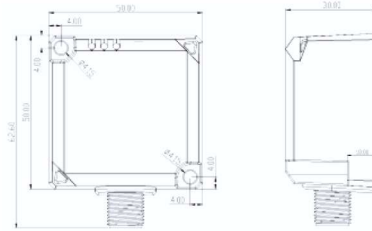

The MRF-HQ50 product is a high frequency integrated industrial RFID Read/Write Device that supports RS485 or Ethernet and can use standard MODBUS Protocol. Using 2 M4 nuts to fix, this Series product has good reading performance, long distance and high Protection Level, which is suitable for automated production process in all walks of life.

Specification

Model	MRF-HQ50	MRF-HQ50-TP
Distance to read	0~80mm(Related to Labels)	
Communication Port	RS485	MODBUS TCP
Protocol	MODBUS RTU	MODBUS TCP
Communication rate	9600~115200 bits/s	10M/100M self-adaptation
Voltage	9-30VDC	
Current	<0.07A@24VDC	
LED	5 × LED	

Physical parameters

Dimensions	50x50x30mm	
Port	M12 Acode 5PIN Male	M12 Acode 8PIN Male
Fixed type	2 M4 screw holes	
Housing material	PC+ABS	
Housing color	Black	
Weight	120g	

Radio frequency (RF) parameters

Protocol	ISO 15693、ISO 14443A
Operating frequency	13.56MHz
Output power	27.5dBm
Wireless rate	26.48Kbit/s

Enironmental adaptation

Operating temperature	-20C~+70°C
Storage temperature	-25°C~+85°C
Humidness	5%~95%RH(no condensation)
Protection Level	IP67
Ant-Vibration	2 mm (f= 5...29.5 Hz) , EN 60068-2-6,7 gn (f= 29.5...150 Hz) , EN 60068-2-6
Conducted immunity (CS)	10V, IEC 61000-4-6
ESD	Contact discharge, 8KV, air discharge, 15KV, IEC 61000-4-2

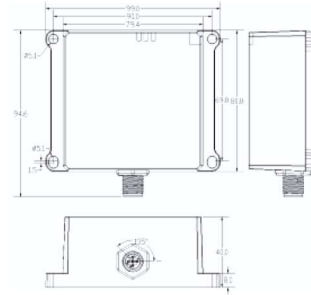

The MRF-HQ80 product is a high frequency integrated industrial RFID Read/Write Device that supports RS485 or Ethernet and can use the standard MODBUS Protocol. Using 2 M5 nuts to fix, this Series product has good reading performance, long distance and high Protection Level, which is suitable for automated production process in all walks of life.

Specification

Model	MRF-HQ80	MRF-HQ80-TP
Distance to read	0~110mm(Related to Labels)	
Communication Port	RS485	MODBUS TCP
Protocol	MODBUS RTU	MODBUS TCP
Communication rate	9600~115200 bits/s	10M/100M self-adaptation
Voltage	9-30VDC	
Current	<0.07A@24VDC	
LED	4 × LED	

Physical parameters

Dimensions	100x80x40mm	
Port	M12 Acode 5PIN Male	M12 Acode 8PIN Male
Fixed type	2 M5 screw holes	
Housing material	PC+ABS	
Housing color	Black	
Weight	270g	

Radio frequency (RF) parameters

Protocol	ISO 15693、ISO 14443A
Operating frequency	13.56MHz
Output power	27.5dBm
Wireless rate	26.48Kbit/s

Enironmental adaptation

Operating temperature	-20C~+70°C
Storage temperature	-25°C~+85°C
Humidness	5%~95%RH(no condensation)
Protection Level	IP67
Ant-Vibration	2 mm (f= 5...29.5 Hz) , EN 60068-2-6,7 gn (f= 29.5...150 Hz) , EN 60068-2-6
Conducted immunity (CS)	10V, IEC 61000-4-6
ESD	Contact discharge, 8KV, air discharge, 15KV, IEC 61000-4-2

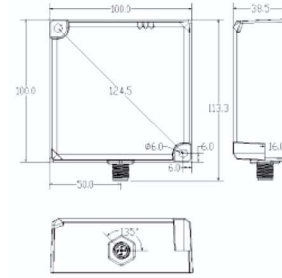

The MRF-HQ100 product is a high frequency integrated industrial RFID Read/Write Device that supports RS485 or Ethernet and can use standard MODBUS Protocol. Using 2 M6 nuts to fix, this Series product has good reading performance, long distance and high Protection Level, which is suitable for the automatic production process of all walks of life.

Specification

Model	MRF-HQ100	MRF-HQ100-TP
Distance to read	0~110mm(Related to Labels)	
Communication Port	RS485	MODBUS TCP
Protocol	MODBUS RTU	MODBUS TCP
Communication rate	9600~115200 bits/s	10M/100M self-adaptation
Voltage	9-30VDC	
Current	<0.07A@24VDC	
LED	4 × LED	

Physical parameters

Dimensions	100x100x39mm	
Port	M12 Acode 5PIN Male	M12 Acode 8PIN Male
Fixed type	2 M6 screw holes	
Housing material	PC+ABS	
Housing color	Black	
Weight	380g	

Radio frequency (RF) parameters

Protocol	ISO 15693、ISO 14443A
Operating frequency	13.56MHz
Output power	27.5dBm
Wireless rate	26.48Kbit/s

Enironmental adaptation

Operating temperature	-20C~+70°C
Storage temperature	-25°C~+85°C
Humidness	5%~95%RH(no condensation)
Protection Level	IP67
Ant-Vibration	2 mm (f= 5...29.5 Hz) , EN 60068-2-6,7 gn (f= 29.5...150 Hz) , EN 60068-2-6
Conducted immunity (CS)	10V, IEC 61000-4-6
ESD	Contact discharge, 8KV, air discharge, 15KV, IEC 61000-4-2

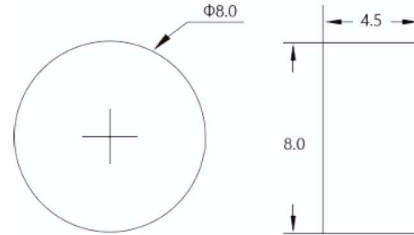

Specification

Model	MD8-128B	MD8M-128B	MD8-2K	MD8M-2K
Operating frequency	13.56MHz			
Protocol	ISO 15693			
Distance to read	0-8mm(Related to Read/Write Device)			
User memory	112 bytes		2000 bytes	
Memory type	EEPROM		FRAM	
Read/Write cycles	100,000 times		10 billion times	
Data retention time	Ten years			
Dimensions	$\phi 8 \times 4.5$ mm			
Housing material	PBT			
Fixed Type	Glue			
Protection Level	IP68			
Operating temperature	-40 ~ 70°C			
Storage temperature	-40 ~ 125°C			
Installation	Metal-free (clear zone)	on metal	Metal-free (clear zone)	on metal

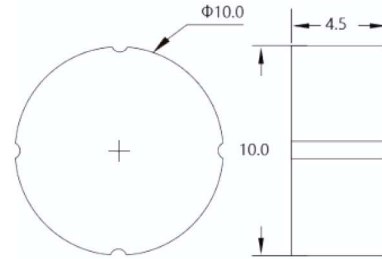
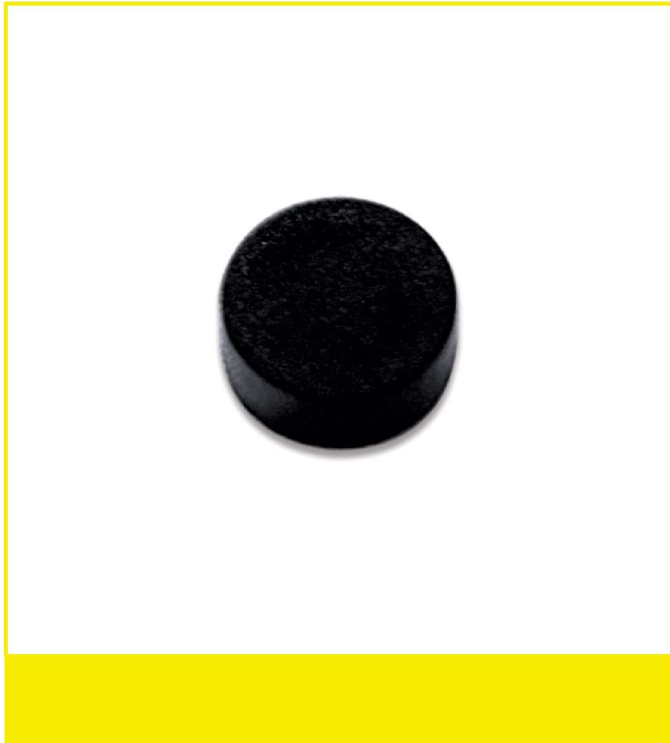

Specification

Model	MD10-128B	MD10M-128B	MD10-2K	MD10M-2K
Operating frequency	13.56MHz			
Protocol	ISO 15693			
Distance to read	0-12mm(Related to Read/Write Device)			
User memory	112 bytes		2000 bytes	
Memory type	EEPROM		FRAM	
Read/Write cycles	100,000 times		10 billion times	
Data retention time	Ten years			
Dimensions	φ10*4.5mm			
Housing material	PBT			
Fixed Type	Glue			
Protection Level	IP68			
Operating temperature	-40 ~ 70°C			
Storage temperature	-40 ~ 125°C			
Installation	Metal-free (clear zone)	Flush in metal	Metal-free (clear zone)	Flush in metal

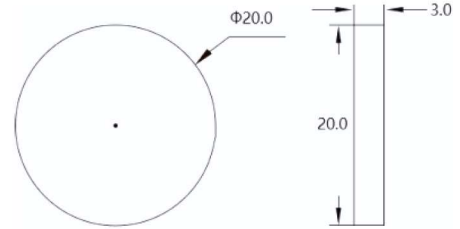

Specification

Model	MD20-128B	MD20M-128B	MD20-2K	MD20M-2K
Operating frequency	13.56MHz			
Protocol	ISO 15693			
Distance to read	0-50mm(Related to Read/Write Device)			
User memory	112 bytes		2000 bytes	
Memory type	EEPROM		FRAM	
Read/Write cycles	100,000 times		10 billion times	
Data retention time	Ten years			
Dimensions	φ20*3mm			
Housing material	PPS			
Fixed Type	Glue			
Protection Level	IP67			
Operating temperature	-40 ~ 70°C			
Storage temperature	-40 ~ 125°C			
Installation	Metal-free (clear zone)	on metal	Metal-free (clear zone)	on metal

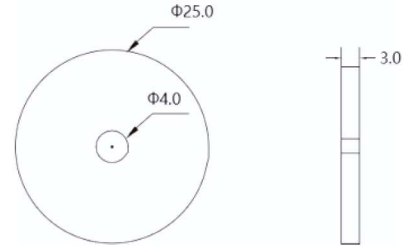

Specification

Model	MD25-128B	MD25M-128B	MD25-2K	MD25M-2K
Operating frequency	13.56MHz			
Protocol	ISO 15693			
Distance to read	0-80mm(Related to Read/Write Device)			
User memory	112 bytes		2000 bytes	
Memory type	EEPROM		FRAM	
Read/Write cycles	100,000 times		10 billion times	
Data retention time	Ten years			
Dimensions	φ25*3mm			
Housing material	PPS			
Fixed Type	Screw fixing			
Protection Level	IP67			
Operating temperature	-40 ~ 70°C			
Storage temperature	-40 ~ 125°C			
Installation	Metal-free (clear zone)	on metal	Metal-free (clear zone)	on metal

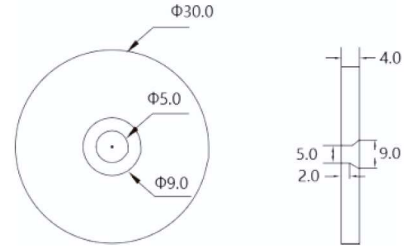

Specification

Model	MD30-128B	MD30M-128B	MD30-2K	MD30M-2K
Operating frequency	13.56MHz			
Protocol	ISO 15693			
Distance to read	0-100mm(Related to Read/Write Device)			
User memory	112 bytes		2000 bytes	
Memory type	EEPROM		FRAM	
Read/Write cycles	100,000 times		10 billion times	
Data retention time	Ten years			
Dimensions	φ30*4mm			
Housing material	PPS			
Fixed Type	Screw fixing			
Protection Level	IP67			
Operating temperature	-40 ~ 70°C			
Storage temperature	-40 ~ 125°C			
Installation	Metal-free (clear zone)	on metal	Metal-free (clear zone)	on metal

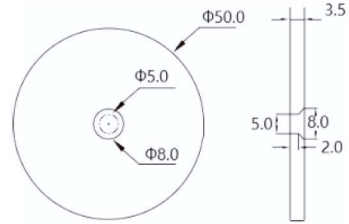

Specification

Model	MD50-128B	MD50M-128B	MD50-2K	MD50M-2K
Operating frequency	13.56MHz			
Protocol	ISO 15693			
Distance to read	0-150mm(Related to Read/Write Device)			
User memory	112 bytes		2000 bytes	
Memory type	EEPROM		FRAM	
Read/Write cycles	100,000 times		10 billion times	
Data retention time	Ten years			
Dimensions	φ50*3.5mm			
Housing material	PPS			
Fixed Type	Screw fixing			
Protection Level	IP67			
Operating temperature	-40 ~ 70°C			
Storage temperature	-40 ~ 125°C			
Installation	Metal-free (clear zone)	on metal	Metal-free (clear zone)	on metal